

Mission: *To develop lifelong learners through effective teaching in a safe and caring environment.*
Vision: *Educational excellence for every child – setting the standard others aim for.*

AGENDA
BOARD OF EDUCATION – SPECIAL MEETING
Instructional Planning Center/Huron Arena
August 26, 2015
5:30 p.m.

1. **Call to order**
2. **Roll call**
3. **Pledge of Allegiance**
4. **Adoption of the agenda**
5. **Dates to Remember**

August 27	Freshman Day/8:00 a.m. – 1:30 HHS Commons
August 27	9 th Grade Orientation/6:00 p.m. – 10:00 p.m.
	*6:00 – 8:00 – iPad Checkout and School Pictures
	*8:00 – 10:00 MANDATORY Parent/Student Orientation
Aug 31-Sept 3	All-Teacher In-Service
August 31	Elementary Open House
	▪ Kindergarten - Buchanan/4:30-5:30
	▪ 1 st Grade - Buchanan / 4:30-5:30
	▪ 2 nd Grade-Madison/5:30-6:30
	▪ 3 rd Grade-Madison/5:30-6:30
	▪ 4 th Grade-Washington/6:30-7:30
	▪ 5 th Grade-Washington/6:30-7:30
September 1	All-Staff Luncheon – 11:30 High School Commons
September 1	Middle School Welcome Back
	▪ 6 th @ 5:00
	▪ 7 th @ 6:00
	▪ 8 th @ 7:00
Sept 3-Sept 7	South Dakota State Fair
September 8	First Day of School for 1 st through 12 th
September 8-11	Kindergarten Screening
September 14	First Day of School for Kindergarteners
September 14	High School Open House /6:40
September 23	Early Release
September 21	Goals Work Session w/Administrators 7:00 P.M. - IPC
October 2	Homecoming / Early Release
October 5	HHS Parent /Teacher Conferences 5:30-8:45
October 7	Early Release
October 12	Native American Day – No School
6. **Community Input on Items Not on the Agenda**

7. CONSENT AGENDA

The superintendent of schools recommends approval of the following:

a) Board Approval of New Hires

As was mentioned previously, classified personnel and substitute teachers/classroom aides must be approved in order to be covered by our workers' compensation plan.

- 1) Rita Schultz / Administrative Assistant to HMS Counselor / \$14.28 per hr
- 2) Rhonda Nelson / TAP Program-Substitute Classroom Leader / \$16.22 per hr
- 3) Kendall Leichtenberg / SPED Para @ HMS / \$12.81 per hr
- 4) Brandi Blue / SPED Para @ Madison / \$12.96 per hr
- 5) Sammie Bryant / ESL Para Educator / \$12.96 per hr
- 6) Kama Paw / Student Interpreter / \$12.55 per hr
- 7) Edsson Quispe-Laura / Student Interpreter / \$12.55 per hr

b) Contracts for Board Approval

- 1) Hannah Dean / Revised +15 hr / \$1,500.00
- 2) Michelle Azar / Instructor / Teacher 4th/5th Gr Center / \$40,076.00

c) Resignations for Board Approval

- 1) Brenda Cross / Food Service Sub
- 2) Whitney Easton / Winter Sideline Cheer Coach
- 3) Emily Forbush / SPED Para-Educator – 4 yrs/8th Gr Girls BB Asst Coach
- 4) Jean Montgomery-Della Rocco / ESL Para-Educator / 2 years

d) Request for Approval of Open Enrollment Request

The administration has received open enrollment request #OE-2015-5, #OE-2015-6, #OE-2015-7, #OE-2015-8, #OE-2015-9, and #OE-2015-10 for Board approval.

e) Request to Open Activity Account

Terry Rotert, Activities Director, is requesting to open a Boys Tennis Activity Account. Letter attached.

f) Delta Dental Renewal

Information is included – 3.3% rate increase

(The consent agenda may be approved with one motion. However, if a board member wishes to separate an item for discussion, he may do so.)

8. CELEBRATE SUCCESSES IN THE DISTRICT:

CONGRATULATIONS:



THANK YOU TO:

- Huron Chamber & Visitors Bureau/Lucky Duck/Buchanan School \$500 Winner
- Custodians, Buildings & Grounds Employees – Move to Washington

9. REPORTS TO THE BOARD

a) GOOD NEWS:

- **School Nutrition Program** – Carol Tompkins, Director
- **Summer Feeding Program** – Karla Sawvell, Team Leader/Middle School
- **Summer School** – Kari Hinker, Director of ESL Program/Federal Programs

b) Business Manager's Report

c) Superintendent's Report

- Teacher Reassignment Based on Enrollment
(Madison 2nd Grade to Buchanan Kindergarten)
- Additional 5th Grade Teacher
- Advertising for Additional Kindergarten Teacher
- Data Retreat
- State Report Card
- Open Houses as Scheduled
- Moving Day – Washington Teachers
 - Pictures on Superintendent's Facebook Page
- New Staff Orientation
- All-Staff Luncheon – Tuesday, September 1st
- Website Development

10. OLD BUSINESS

- a) **1st Reading – Policy KG – Arena and Tiger Stadium Custodial Fees**
- b) **Veteran's Policy Update**
- c) **Policy DO Update – Expense Reimbursement (Lodging, Mileage, and Meals)
(Changed by Board 7-13-15, Effective 7-1-15) Mileage from .15 to .18 cents.**

11. NEW BUSINESS

- a) **Washington Change Order No. G-4 - \$10,267.00**
- b) **Guidelines for iPad Use – Huron Middle School**

12. EXECUTIVE SESSION

- 1-25-2 Executive or closed meetings may be held for the sole purpose of:
- (5) Discussing marketing or pricing strategies by a board or commission of a business owned by the state or any of its political subdivisions, when public discussion may be harmful to the competitive position of the business.

13. ADJOURNMENT

Huron School District
New Hire Justification

Date: 8/17/15

Applicant Information

Applicant Name: Rita Schulz

Address: 876 13th St. SW Huron, SD 57350

Phone: 605-695-0282

Education: Nettleton College Sioux Falls, SD

Experience: Sr. Secretary; SD Board of Pharmacy 2012-present
College of Pharmacy @ SDSU: Program Assistant 2006-2012

References: College of Nursing @ SDSU: Sr. Secretary 2001-2006
Gary Karel
Dennis Wedge
Randy Jones
Marlene Soeklander
Vickie Prussman

Reason for New Hire

New Position:

Replacement: Randi Papka position, who moved to Adm. Assistant
in Principal's office

Position Information

Department: Counseling

Position: Secretary

Supervisor: Heather Sieh

Responsibilities: Scheduling of students; Assist testing; Monthly
Calendar + Super Kids; Quarterly newsletter, SAFE/Sol

Hours: 5 hrs./day or 25 hrs./week

Hiring Information

Wages: \$14.28 Step 5

Classification: AA

Wage Justification: College hrs. + yrs. experience.
Per conversation w/ Mr. Nebelsick

Start Date: Aug. 31, 2015; must give 2 week notice, so
(Administrator)

Requested by: M. Taplett could be after this date.
Teacher contracted days
180.5

**Huron School District
New Hire Justification**

Date: 8/18/15

Applicant Information

Applicant Name: Rhonda Nelson

Address: 215314 410th St. Cavour, SD

Phone: 605-350-1037

Education: High School

Experience: Desk Clerk and Front end supervisor

References: jenny Mallard and Sheila Anderson

Reason for New Hire

New Position: NA

Replacement:

Position Information

Department: Tiger After-School Program

Position: Substitute Classroom Leader at various sites

Supervisor: Gay Pickner

- **Responsibilities:** Classroom leader will assist in delivering 30-90 minutes of reading, math, and science instruction daily using the adopted curriculum. Leaders will maintain records to assist with evaluating the effectiveness of the TAP.

Hours: 3:30-5:30 (days/hours will vary)

Hiring Information

Wages: \$16.22

Classification:

Wage Justification:

Start Date: September 21, 2015

Requested by: Gay Pickner

(Administrator)

**Huron School District
New Hire Justification**

Date: 8/20/15

Applicant Information

Applicant Name: Kendall Leichtenberg

Address: 420 Quapaw Street S., Iroquois, SD 57353

Phone: 605-864-8419

Education: 2 years post secondary

Experience: 0 Year

References: Tom Hager, April Leichtenberg, Jom Mattern

Reason for New Hire

New Position: SPED Para at Middle School

Replacement: New Hire

Position Information

Department: SPED

Position: Para at Middle School

Supervisor: Amanda Kuntz

Responsibilities: SPED Para

Hours: 7.5 Hours

Hiring Information

Wages: \$12.81

Classification: Step Zero

Wage Justification: No previous experience

Start Date: Fall 2015

Requested by: Lori Wehlander (Administrator)

8/25/14

**Huron School District
New Hire Justification**

Date: 8/20/15

Applicant Information

Applicant Name: Brandi Blue

Address: 305 North Yale Street, Yale, SD 57386

Phone: 605-461-9239

Education: 2 years post secondary

Experience: 1 Year

References: Erica Fast, Cathy Ramsell, Pat Decker

Reason for New Hire

New Position: SPED Para at Madison

Replacement: New Hire

Position Information

Department: SPED

Position: Para at Madison

Supervisor: Barb Myhre

Responsibilities: SPED Para

Hours: 7.5 Hours

Hiring Information

Wages: \$12.96

Classification: Step One

Wage Justification: 1.5 years at Center for Independence and .5
Year Para at Iroquois

Start Date: Fall 2015

Requested by: Lori Wehlander (Administrator)

**Huron School District
New Hire Justification**

Date: August 20, 2015

Applicant Information

Applicant Name: Sammie Bryant

Address: 1590 McClellan Dr

Phone: 605-354-2617

Education: Early Childhood Education-36 credit hours at Ashford University and NSU

Passed Para Pro test

Experience: Vocational Instructor at Huron Area Center for Independence

References: Lisa Kissner, Kristen Jaqua, Kim Seiler

Reason for New Hire

New Position: New position based on ESL numbers at the 2/3

Center

Replacement:

Position Information

Department: ESL

Position: Para Educator

Supervisor: Heather Rozell, Kari Hinker

Responsibilities:

- Work with small groups of students under the supervision of a classroom teacher
- Assist teachers in the classroom to reinforce skills taught
- Read to students and listen to students read
- To provide explanation and help for students in English

Hours: 7:50-3:20

Hiring Information**Wages:** \$12.96**Classification:** Class A, Step 1**Wage Justification:** one year experience at Center for Independence**Start Date:** September 8, inservice days as allowable with her 2
week notice**Requested by:** Kari Hinker, Heather Rozell
(Administrator)

8/2014

TEACHER'S CONTRACT
Huron School District No. 2-2, Huron, South Dakota

Hannah Dean

August 20, 2015

YOU ARE HEREBY OFFICIALLY NOTIFIED, that you have been elected as a **Teacher** in the Huron School District No. 2-2, whose address is City of Huron on the annual salary basis of \$ 37983 for the school term, or the remaining part thereof, of the designated number of teaching days, inclusive of days arranged for pre-school planning, beginning 8/31/2015 and subject to the calendar, or modifications of the same, as adopted by the Board of Education. The salary is to be paid the twentieth day of each of the twelve calendar months.

Your election is subject to the school laws of the State of South Dakota and to the salary schedule and contractual elements rules and regulations of the Board of Education of the Huron School District No. 2-2, which are hereby by reference, incorporated in and made a part of this contract as though set forth herein at length, subject to the right of said Board to terminate the contract for cause, to be determined upon by the Board.

It is further contracted and agreed that your failure to complete the term of teaching prescribed herein for any cause, including but not limited to dismissal or resignation, constitutes a financial damage to the Huron School District No. 2-2 and that from the nature of the case it might be impractical or difficult to fix the actual damage. **THEREFORE**, it is understood and agreed that your failure to complete the term provided herein shall result in the following liquidated damages: failures occurring between the date signed and approved by the School Board through June 30 for the ensuing year, damages shall be assessed at \$1,000.00. For breaking a contract July 1 through July 31, damages shall be assessed at \$2,000.00 and breaking of contract August 1 and for the duration of the first semester, damages shall be assessed at \$3,000.00. Damages will be assessed at \$1,500.00 for breaking of a contract anytime during the 2nd semester. The Board reserves the right to request the Department of Education to suspend the employee's certification for one year in lieu of monetary damages in accordance with SDCL 13-42-9. Teachers who are not full-time employees of the District shall be assessed damages at a percentage which matches their percent of employment.

It is further understood and agreed that resignations shall not become effective until approved by the Board of Education at the next meeting following receipt of said resignation. Further, it is hereby agreed that you will pay to the Huron School District No. 2-2, or the Huron School District No. 2-2 will withhold or appropriate from any monies owed by them to you, and you hereby authorize such withholding or appropriation, the appropriate sum herein above set forth as liquidated damages due to your failure to complete said term.

This agreement becomes a binding contract when signed by the teacher and the Board of Education.

BS+15
Hired 2013-14/BS w/no formal experience;

Agreeing to this contract includes the following: Teachers new to the District are expected to work an additional 5 days beginning August 24. During this time, the teacher will receive appropriate training in District programs, and will have time to become adequately prepared for the new school year.

For those electing the Wellness Benefit, an additional \$500 will be paid in September. The benefit is NOT reflected in the contract total.

SCHOOL DISTRICT NO. 2-2 OF THE CITY OF
HURON, BEADLE COUNTY, SOUTH DAKOTA

ATTEST:

.....
Business Manager of the School District

By
Chairman of School District Board

TO THE BOARD OF EDUCATION OF THE HURON SCHOOL DISTRICT NO. 2-2
CITY OF HURON, BEADLE COUNTY, SOUTH DAKOTA

I hereby accept the position mentioned in the foregoing contract of hiring in the Public Schools of Huron, South Dakota, at the salary and upon and under the terms and conditions of the above and foregoing contract and have carefully read said contract and am fully informed as to the contents. I agree to attend such pre-school planning days as are scheduled exclusive of the designated number of teaching days. "I clearly understand that it is my responsibility to be fully certified with the State of South Dakota for the duration of this contract. I accept that my pay will cease on October 1, and my employment may be terminated or suspended without pay until such time that I meet the certification requirements of the job."

Witness my hand this 21st day of August 2015
Witness: Dolly Venables.....

Sign here: Hannah Dean.....
Teacher

TEACHER'S CONTRACT
Huron School District No. 2-2, Huron, South Dakota

Michelle Azar

August 24, 2015

YOU ARE HEREBY OFFICIALLY NOTIFIED, that you have been elected as a **Teacher** in the Huron School District No. 2-2, whose address is City of Huron on the annual salary basis of \$ **40076** for the school term, or the remaining part thereof, of the designated number of teaching days, inclusive of days arranged for pre-school planning, beginning **08/24/2015** and subject to the calendar, or modifications of the same, as adopted by the Board of Education. The salary is to be paid the twentieth day of each of the twelve calendar months.

Your election is subject to the school laws of the State of South Dakota and to the salary schedule and contractual elements rules and regulations of the Board of Education of the Huron School District No. 2-2, which are hereby by reference, incorporated in and made a part of this contract as though set forth herein at length, subject to the right of said Board to terminate the contract for cause, to be determined upon by the Board.

It is further contracted and agreed that your failure to complete the term of teaching prescribed herein for any cause, including but not limited to dismissal or resignation, constitutes a financial damage to the Huron School District No. 2-2 and that from the nature of the case it might be impractical or difficult to fix the actual damage. **THEREFORE**, it is understood and agreed that your failure to complete the term provided herein shall result in the following liquidated damages: failures occurring between the date signed and approved by the School Board through **June 30** for the ensuing year, damages shall be assessed at \$1,000.00. For breaking a contract **July 1** through **July 31**, damages shall be assessed at \$2,000.00 and breaking of contract August 1 and for the duration of the first semester, damages shall be assessed at \$3,000.00. Damages will be assessed at \$1,500.00 for breaking of a contract anytime during the 2nd semester. The Board reserves the right to request the Department of Education to suspend the employee's certification for one year in lieu of monetary damages in accordance with SDCL 13-42-9. Teachers who are not full-time employees of the District shall be assessed damages at a percentage which matches their percent of employment.

It is further understood and agreed that resignations shall not become effective until approved by the Board of Education at the next meeting following receipt of said resignation. Further, it is hereby agreed that you will pay to the Huron School District No. 2-2, or the Huron School District No. 2-2 will withhold or appropriate from any monies owed by them to you, and you hereby authorize such withholding or appropriation, the appropriate sum herein above set forth as liquidated damages due to your failure to complete said term.

This agreement becomes a binding contract when signed by the teacher and the Board of Education.

MA
Hired 2015-2016 w/MA + 8 yrs exp / 4th-5th Gr Reading Interventionary or 5th Gr Classroom Teacher as per Superintendent Directive on 8/26/2015;

Agreeing to this contract includes the following: Teachers new to the District are expected to work an additional 5 days beginning August 24. During this time, the teacher will receive appropriate training in District programs, and will have time to become adequately prepared for the new school year.

For those electing the Wellness Benefit, an additional \$500 will be paid in September. The benefit is NOT reflected in the contract total.

SCHOOL DISTRICT NO. 2-2 OF THE CITY OF
HURON, BEADLE COUNTY, SOUTH DAKOTA

ATTEST:

.....
Business Manager of the School District

By
Chairman of School District Board

TO THE BOARD OF EDUCATION OF THE HURON SCHOOL DISTRICT NO. 2-2
CITY OF HURON, BEADLE COUNTY, SOUTH DAKOTA

I hereby accept the position mentioned in the foregoing contract of hiring in the Public Schools of Huron, South Dakota, at the salary and upon and under the terms and conditions of the above and foregoing contract and have carefully read said contract and am fully informed as to the contents. I agree to attend such pre-school planning days as are scheduled exclusive of the designated number of teaching days. "I clearly understand that it is my responsibility to be fully certified with the State of South Dakota for the duration of this contract. I accept that my pay will cease on October 1, and my employment may be terminated or suspended without pay until such time that I meet the certification requirements of the job."

Witness my hand this 24 day of August, 2015

Witness: Heath Ritz

Sign here: Michelle Azar
Teacher

Good morning.

As we discussed on the phone, please accept this as my resignation letter effective August 17, 2015. I have decided to pursue a position with more firm hours and something in an office setting. Thank you.

Brenda M. Cross

Whitney Easton
whitney.easton@k12.sd.us

August 20, 2015

Terry Rotert
Huron Athletic Director

Dear Terry,

I am writing this to formally notify you that I am resigning from my position as Winter sideline Cheer Coach. Due to recent unforeseen circumstances, I will no longer be able to comply with the numerous responsibilities that are required of me at this time.

I appreciate the opportunities I was given as the cheer coach. Thank you for your guidance and support during my first season. I wish the program a successful future!

Sincerely,

Whitney Easton

Dear Mrs. Moon,

Please accept this letter as formal notification that I am resigning from my position as a Special Education Para-Educator, and 8th Grade Girls Basketball Assistant coach with the Huron High School. My last day at the school will be Friday, August 21st 2015.

Thank you so much for the opportunity to work in this position for the past 3 years. I've greatly enjoyed and appreciated the opportunities you gave me at the high school and all of the things that I have learned I will take with me throughout my career.

During my last few days, I'll do everything possible to wrap up my duties and clean out my room. Please let me know if there's anything else I can do to aid during the transition. I wish nothing but the best for you and the high school, and I appreciate all that you and the school has done for me.

Sincerely,

Emily J Forbush

A handwritten signature in cursive script that reads "Emily J. Forbush". The signature is written in black ink and is positioned below the typed name.

-----Original Message-----

From: Montgomery, Jean

Sent: Friday, August 21, 2015 2:18 PM

To: Nebelsick, Terry; Moon, Demi; Hinker, Kari; Briggs, Becca

Subject: Resignation

Good afternoon to all, I am writing to inform you that I will be leaving my position as Para-Educator at Huron High School. I have been offered a better paying position with more hours and at this time I cannot turn it down. I will turn in the school iPad to the help desk at the high school next week.

I have so thoroughly enjoyed my time with all of my colleagues and the students at Huron High School. It has been a rewarding and at the same time, fun position as a Para-Educator. I want to personally thank you for the professional time you have given me. Go Tigers and all the best for a wonderful 15/16 school year! Take Care.

Kind Regards,

Jean E Montgomery Della Rocco



HURON

HURON ACTIVITIES DEPARTMENT

Terry Rotert, Activities Director / Arena Manager
Huron Arena PO Box 949 Huron, SD 57350
Phone: (605) 353-6970 Fax: (605) 353-6973



TIGERS

DATE: August 6, 2015
TO: Huron School Board Members
Supt. Terry Nebelsick
FROM: Terry Rotert, Activities Director
RE: Boys Tennis Activity Account

On behalf of the boy's tennis program, I am requesting your approval to open an activity account.

At the present time, boy's tennis do not have an account in the business office. I would like to have an account open so the head coach can deposit fundraising money or any other money they may generate in the future.

Thank you for your time and consideration.

Sincerely,

A handwritten signature in black ink that reads "Terry Rotert". The signature is written in a cursive style with a long horizontal line extending from the start of the name.

Terry Rotert

August 7, 2015

Kelly Christopherson
Huron School District
PO Box 949
Huron, SD 57350-0949

Dear Kelly:

Our mission at Delta Dental of South Dakota, is dedicated to advancing and promoting the improvement of oral health. January 1, 2016 begins your 20th year with Delta Dental, and we would like to thank you for doing business with us and we look forward to serving you another year!

We determine your dental rates based on your company's experience. Currently, your expenses are running 1.6% higher than premiums. Based on this, along with the six percent increase in dental costs (i.e., the combination of dental fees and utilization increases), our rate renewal analysis suggested a 10.5% increase in rates. However, we take a long term approach to rate setting and are committed to keeping group rates as stable as possible, and in support of these values, we have limited your rate increase to just 3.3%. Your rates for this year are:

2016 Rates

Single	\$44.10	(increase of \$1.40)
Two-Party	\$84.94	(increase of \$2.72)
Three-or-More	\$135.16	(increase of \$4.32)

If you would like additional information on your company's experience or for information on ways to reduce your rates through increased deductibles, changes to coinsurance or other benefit changes, please contact me directly at (605) 494-2540.

We want you to know that we appreciate the trust you place in Delta Dental to provide a dental benefits program for your employees. You join nearly 1,700 other South Dakota employers who also trust us to maintain healthy smiles for their employees. We are proud to be a South Dakota-based company.

Sincerely,

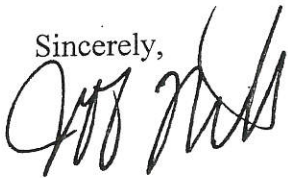

Jeff Miller
Vice President of Underwriting & Compliance

2015-2016 School Nutrition Good News Report

Our Exciting New Kitchens at Madison 2-3 Center and Washington 4-5 Center:

We are excited about and were in our two new kitchens today cleaning and preparing for the start of school and are really glad to have our new equipment and wonderfully updated facilities. **THANK YOU!**

Grant Updates:

USDA Fresh Fruit and Vegetable Grant awarded to our three Huron elementary centers for the 2015-2016 school year. The total award amount is \$70,059.00. In SD there were 74 districts awarded this grant and the grants will serve 128 school sites.

The Arby's School's Out, Foods In Summer Meals Grant was \$3,000.00 in total and was used over the summer months to allow children the opportunity to have transportation to attend our summer nutrition program. We used \$2,500.00 to run a yellow school bus to seven various stops and back each day in Huron from July 6th through August 7th.

Our bus schedule allowed access to ride from all points of Huron:

<u>AM Schedule: TIME</u>	<u>ADDRESS</u>
11:10	4 th & Mellette SW
11:17	5 th & Ohio NW
11:22	5 th & Kansas NE
11:29	8 th & Frank SE
11:33	7 th & Illinois SW
11:39	20 th St. SE—Townhouse Apts.
11:45	Middle School—Front Doors

PM Schedule: Middle School pickup @ 12:15ish pm

12:24	20 th St. SE – Townhouse Apts.
12:34	7 th & Illinois SW
12:34	8 th & Frank SE
12:41	5 th & Kansas NE
12:46	5 th & Ohio NW
12:53	4 th & Mellette SW

For years we have wondered if we were to be able to fund bussing the children from other areas all around Huron if we would serve more lunches and more of our community. Without the funding to try it we have not been able until this year to even guess whether if it would be a successful endeavor or not. We are grateful to have obtained this grant which allowed us the opportunity to finally try bussing in the summer for our program. It was successful in that the children that the small number of children who rode the bus came did come fairly often to lunch, but our total numbers of riders during the 5 weeks was only 44 in total. Clearly not enough to sustain a summer bussing program without benefit of a grant.

Thanks to the ESL Program in June and possibly some students attending by riding our yellow bus we are up only 72 meals; a very slight increase over last year's total numbers of meals. Average meals per day was a respectable 339 over the 44 days of the program.

Staffing:

School nutrition is going into the new school year fully staffed and we have even picked up a couple new food service substitutes.

USDA Regulations:

The Healthy Hunger Free Kids Act of 2010 is now in its last year. USDA and Congress address will reauthorize funding for our federal child nutrition programs as they do every five years. 2015 is also the year for announcing the newest Dietary Guideline for Americans which encourages eating a healthful diet. We also will elect a new President and congress and both play roles in our program funding and reauthorization...it could be an interesting reauthorization period...stay tuned.

Professional Training for All School Nutrition Program Staff:

The final piece of the Healthy Hunger Free Kids Act of 2010 will ensure school nutrition personnel have the knowledge, training, and tools to plan, prepare, and purchase products to create nutritious, safe, and enjoyable meals.

We are ready to roll out our staff training plan as soon as school begins and have a plan for each of the individual staff members for hours needed to train and what the individual training emphasis for them specifically will be.

Menu Changes:

Our menus are ready and we have made some changes that we hope students will like for example:

Breakfasts were changed up a bit by adding a couple items sampled with students last year and we are adding pancake and sausage on a stick and blueberry muffins to breakfast.

Lunch menus have changed too. We added roast pork loin w/ baby baker potatoes, bringing back Italian dunkers w/pizza sauce, adding macaroni & cheese again w/ hot dogs, bringing back BBQ rib patty sandwich, smiles potatoes, and tri taters.

Manufacturers have done better at lowering calories and sodium which in turn has allowed us room in calories and sodium to add back in more condiments to our menus. Coming back this fall are mustard, pickle slices, sliced fresh onions, and parmesan cheese.

We are slightly expanding the offerings each day on our vegetable bar at MS and HS by adding fresh tomatoes and fresh cucumbers every day.

Week of Menus:

Here is a summary of our school menu planning. I hope this explanation will allow you and parents to understand the planning of school lunches.

I have given you one week's elementary menu (which just happens to be week #2) from our six week cycle menu. The targets we need to hit each week are completely different by age group for elementary, MS, and HS. We figure 27 separate weekly menus including all breakfast and lunch menus district wide.

This "colorful" menu shows what the menu items will be for each day, the portions of each, how many ounces breads/grains are served for the day, how many ounces of meat are served for the day, total servings of fruit and vegetables for each day **and** what color group the vegetables are in for each day. It also shows total calories, total fat, saturated fat, sodium, sugar, fiber, Trans fat, and if the item served is whole grain. The three yellow totals lines at the bottom of each day of the week reflect which type of milk a student may choose.

On the third page please see "weekly targets" these are our targets to hit exactly or be under as an average for the week. Note bread target says 8 to 9 per week and we are at 12 this week. Same with meat it says 8 to 10 per week and we are at 10.5. USDA relaxed these areas and we must provide the minimum amount required but are allowed to over in only these two areas. We have done so to better meet total calories and provide more well rounded nutritious meals.

Calories must be between 550/650 per day as an average at this grade level and are at 639 average if a student chooses chocolate skim milk...we try to get as close to the high calorie limit allowed to offer the most food to students and still be inside our targets.

Total fat and saturated fat are all well below our target. Trans fat must be zero. Sodium is a challenge to stay under and we have done so while hitting all required targets and menu items. Sugar and fiber have no targets *yet*, but we list them anyway on our menus.

Fruit needs to be served in differing total target amounts for each grade level.

Lastly, please note the colors for the vegetables that say dark green, red/orange, Legumes, starchy, and additional vegetable. Each grade level again has differing total target amounts of vegetables that need to be served each week; plus in conjunction we need to serve each of these "colors" and "types" of vegetables in specific target amounts each week also.

This was a summary of how our school menus are planned and how we allow for all the target variables. I hope this again helps explain why our menus are planned as we do and appreciate your time.

Are there any questions?

Elementary

#2	Portion	Breads	Meat/Veg	Fruit/Veg	Milk	Calories	Total Fat	Sat Fat	Sodium	Sugar	Fiber	WG	Tran Fats
1 - 3 oz. A+ Meatloaf slice w/ketchup	1					130	6 gm	2.5 gm	460 mg	3 gm	2 gm	N/A	0
1 - Tablespoon Ketchup (Heinz)						20	0	0	160 mg	4 gm	0	N/A	0
1 - Oatmeal Dinner Roll (2 Ounce)	1					144	3.38 gm	.52 gm	188 mg	3.76 gm	2.5 gm	yes	0
1 - 1/4 Cup French Fries (LWest Gen X14)	12 Fries			1/2 Serv		90	1.88 gm	.25 gm	100 mg	.50 gm	1.5 gm	N/A	0
1 - 5 gm Oleo Cup (Whipped)						25	3 gm	.50 gm	30 mg	0	0	N/A	0
1 - 1/2 Cup Fresh Mini Carrots	10 Carrots = 1/2 Cup			1 Serv		26	.014 gm	.22 gm	42 mg	2.90 gm	1.70 gm	N/A	0
1/2 Cup Fruit Cocktail	4 oz slotted spoodle			1 Serv		60	0	0	10 mg	11 gm	0 gm	N/A	0
1 - 8 oz. Skim White					1	90	0	0	130 mg	12 gm	0	N/A	0
1 - 8 oz. 1% White						585	14.28 gm	3.99 gm	1120 mg	37.16 gm	7.70 gm	yes	0
1 - 8 oz. Chocolate Skim					1	110	2.5 gm	1.5 gm	130 mg	12 gm	0	N/A	0
1 - 8 oz. Chocolate Skim						605	16.78 gm	5.49 gm	1120 mg	37.16 gm	7.70 gm	yes	0
1 - 8 oz. Chocolate Skim					1	120	0	0	180 mg	20 gm	0	N/A	0
1 - 8 oz. Chocolate Skim						615	14.28 gm	3.99 gm	1170 mg	45.16 gm	7.70 gm	yes	0

#2	Portion	Breads	Meat/Veg	Fruit/Veg	Milk	Calories	Total Fat	Sat Fat	Sodium	Sugar	Fiber	WG	Tran Fats
1 - Tyson Grill Chic Sand 2.19 oz	1					100	3.5 gm	1 gm	200 mg	0	0	N/A	0
1 - Tablespoon Cookie's BBQ Sauce						18	0	0	105 mg	3.5 gm	.5 gm	N/A	0
1 - Oatmeal Hamb Bun (2 oz)	1					144	3.38 gm	.52 gm	188 mg	3.76 gm	2.5 gm	yes	0
5 oz. spoodle=4 oz.						140	.5 gm	0	370 mg	12 gm	.6 gm	N/A	0
1 - 1/2 Cup Corn (Cooked)	4 oz slotted spoodle			1 Serv		94	.66 gm	0	6 mg	2.66 gm	2.66 gm	N/A	0
1 - 1/2 Cup Sliced Peaches	4 oz slotted spoodle			1 Serv		60	0	0	10 mg	11 gm	0	N/A	0
1 - 8 oz. Skim White					1	90	0	0	130 mg	12 gm	0	N/A	0
1 - 8 oz. 1% White						646	8.1 gm	1.52 gm	1009 mg	44.92 gm	11.66 gm	yes	0
1 - 8 oz. Chocolate Skim					1	110	2.5 gm	1.5 gm	130 mg	12 gm	0	N/A	0
1 - 8 oz. Chocolate Skim						666	10.54 gm	3.02 gm	1009 mg	44.92 gm	11.66 gm	yes	0
1 - 8 oz. Chocolate Skim					1	120	0	0	180 mg	20 gm	0	N/A	0
1 - 8 oz. Chocolate Skim						676	8.1 gm	1.52 gm	1059 mg	52.92 gm	11.66 gm	yes	0

#2	Breads	Meat/VA	Fruit/Veg	Milk	Calories	Total Fat	Sat Fat	Sodium	Sugar	Fiber	WG	Tran Fats
1- 5 oz. Tangerine Chicken (Asian Sol.)	1/2	2 1/2			238	5 gm	1.25 gm	475 mg	16.25 gm	2.5 gm	N/A	0
1- 1/2 Cup Brown Rice, Cooked	1				88	1.34 gm	.17 gm	11 mg	.15 gm	.67 gm	yes	0
1- 1/2 Cup Steamed Carrots (Cooked)			1 Serv		47	.0	.0	80 mg	5.33 gm	2.66 gm	N/A	0
2- Tablespoons Light Ranch Dressing (HV)					7.5	.13 gm	.025 gm	3.75 mg	.53 gm	1 gm	N/A	0
1- 1/2 Cup Pineapple Tidbits			1 Serv		23	.64 gm	.02 gm	211 mg	1.75 gm	.03 gm	N/A	0
1- 8 oz. Skim White				1	64	.0	.0	.0 mg	14 gm	.8 gm	N/A	0
1- 8 oz. 1% White					90	.0	.0	130 mg	12 gm	.0	N/A	0
1- 8 oz. Chocolate Skim					558	7.11 gm	1.47 gm	911 mg	50 gm	7.66 gm	yes	0
				1	110	2.5 gm	1.5 gm	130 mg	12 gm	.0	N/A	0
					578	9.61 gm	3.97 gm	911 mg	50 gm	7.66 gm	yes	0
				1	120	.0	.0	180 mg	20 gm	.0	N/A	0
					588	7.11 gm	1.47 gm	961 mg	58 gm	7.66 gm	yes	0

Portion
5 oz spoodle
#8 scoop
4 oz slotted spoodle
Measure 1 Cup
4 oz slotted spoodle

#2	Breads	Meat/VA	Fruit/Veg	Milk	Calories	Total Fat	Sat Fat	Sodium	Sugar	Fiber	WG	Tran Fats
1- 6 oz. Beefy Mac (Homemade)	1 1/2	2			186	9.5 gm	3.29 gm	225 mg	5.45 gm	1.71 gm	yes	0
1- Multigrain Dinner Roll (2.0ounce)	2				148	3.28 gm	.52 gm	188 mg	3.92 gm	2.58 gm	yes	0
1- 5 gm Oleo Cup (Whipped)					25	.3 gm	.50 gm	30 mg	.0	.0	N/A	0
1- 3/4 Cup Cassia Sprouts			1 1/2 Serv		45	.0	.0	15 mg	.0	3 gm	N/A	0
1- 1 Cup Apple Wedges (6 Wed/Whole)			2 Serv		92	.32 gm	.0	1.98 mg	18.84 gm	4.35 gm	N/A	0
1- 8 oz. Skim White				1	90	.0	.0	130 mg	12 gm	.0	N/A	0
1- 8 oz. 1% White					586	16.1 gm	4.31 gm	590 mg	40.21 gm	11.64 gm	yes	0
1- 8 oz. Chocolate Skim				1	110	2.5 gm	1.5 gm	130 mg	12 gm	.0	N/A	0
					606	18.6 gm	5.81 gm	590 mg	40.21 gm	11.64 gm	yes	0
				1	120	.0	.0	180 mg	20 gm	.0	N/A	0
					616	16.1 gm	4.31 gm	640 mg	48.21 gm	11.64 gm	yes	0

Portion
6 oz spoodle
1
6 oz slotted spoodle
6 wedge/ 1 whole

#2	Ingredients	Portion	Breads	Meat/VA	Fruit/Veg	Milk	Calories	Total Fat	Sat Fat	Sodium	Sugar	Fiber	WG	Tran Fats
	1-3.6 oz Trident WG Fish Sand	1	1	2			190	8 gm	1 gm	190 mg	1 gm	2 gm	yes	0
	1- Oatmeal Hamb Bun(2 oz)	1	2				144	3.38 gm	.52 gm	188 mg	3.76 gm	2.5 gm	yes	0
	1- 1/2 oz. Tartar Sauce						32	1.92 gm	0	135 mg	2.42 gm	0	N/A	0
	2-Tri Taters (2-oz.)	2 each			1 Serv		100	5 gm	1 gm	220 mg	0	2 gm	N/A	0
	1- Tablespoon Ketchup (Heinz)						20	0	0	160 mg	4 gm	0	N/A	0
	1- 1/2 Cup Beans (Coke)				1 1/2 Serv		30	0	0	30 mg	2 gm	2 gm	N/A	0
	1- 1/2 Cup Sliced Pears	6 oz slotted spoodle			1 Serv		60	0	0	10 mg	12 gm	2 gm	N/A	0
	1- 8 oz. Skim-White	4 oz slotted spoodle				1	90	0	0	130 mg	12 gm	0	N/A	0
	1- 8 oz. 1% White						666	18.3 gm	2.52 gm	1063 mg	37.18 gm	16.50 gm		
	1- 8 oz. Chocolate Skim						110	2.5 gm	1.5 gm	130 mg	12 gm	0	N/A	0
							686	20.8 gm	4.02 gm	1063 mg	37.18 gm	16.50 gm		
							120	0	0	180 mg	20 gm	0	N/A	0
							696	18.3 gm	2.52 gm	1113 mg	45.18 gm	16.50 gm		
							Calories	Total Fat	Sat Fat	Sodium	Sugar	Fiber	WG	Tran Fats
			8 to 9	8 to 10	x	Milk	550/650	< 30%	< 10%	1230	0 gm	0 gm	yes	0
			12	10.5	V 4.5 Cup		609/639	S/C 63.89	S/C 13.81	939	210	55.16 gm	yes	0
								1% 76.39	1% 21.31	989	250			

Weekly Targets	Weekly Totals	Vegetables	2.75 Cup Target
Dark Green	1 Cup Romaine lettuce (credits for only 1/2 Cup)		
Red/Orange	1/2 Cup Mini carrots, fresh	S	609 S 18.89 S 4.09 939
Legumes	1/2 Cup Carrots, steamed	1%	629 1% 21.87 1% 6.10 989
Starchy	1/2 Cup Veg Baked Beans	C	639 C 18.00 C 3.90 939
Additional Veg	1/4 Cup French fries		
	1/2 Cup Corn		
	1/4 Cup Tri Taters		
	3/4 Cup California blend		
	3/4 Cup Brussels sprouts		
Fruits	2.50 Cup Target		
	1/2 Cup Fruit cocktail, canned		
	1/2 Cup Peach slices, canned		
	1/2 Cup Pineapple tidbits, canned		
	1 Cup Apple wedges, fresh		
	1/2 Cup Pear slices, canned		

My name is Karla Sawvell, MS kitchen team leader, thank you for this time at tonight's meeting.

Your support again this year as we operated the Summer Food Service Program is very much appreciated. The service dates were June 8 through August 7.

Breakfast was served Monday-Thursday, June 8-July 2. Lunch service was June 8-August 7. The first four weeks of our program was again very busy with students in the ESL summer school joining us for breakfast and lunch. Our program also served the Nordby Center Day Camp children, parents, grandparents, volley ball camp attendees and others from the community, making lunch quick and simple. Total meals served during the course of Summer Feeding were 14,903.

This is a lot of meals and the total number sounds impressive, most importantly however is that students were fed, some of which might not have gotten a meal. For this we thank you for allowing us to succeed in making available to these families exactly what this program offers, nutritious meals during the summer months when the National School Lunch Program is not in operation.

Classes for the 15-16 school year are about to begin and we invite our board members, staff, parents and the community to eat lunch with us any time this year.

Custodial Fees – Policy KG

Arena & Tiger Stadium

Arena Custodial Fees:

	Current	Proposed
○ Monday thru Friday	\$15.00 per hour	\$18.00 per hour
○ Saturday	\$22.50 per hour	\$27.00 per hour
○ Sunday	\$30.00 per hour	\$36.00 per hour

Arena Clean-up Crew Fee:

○ Monday thru Sunday	\$15.00 per hour
----------------------	------------------

Tiger Stadium Custodial Fees:

	Current	Proposed
○ Monday thru Friday	\$15.00 per hour	\$18.00 per hour
○ Saturday	\$22.50 per hour	\$27.00 per hour
○ Sunday	\$30.00 per hour	\$36.00 per hour

Tiger Stadium Clean-up Crew Fee:

○ Monday thru Sunday	\$15.00 per hour
----------------------	------------------

VETERAN'S PREFERENCE

If at the time a veteran submits an application for employment or employment promotion in the District the veteran possesses the qualifications and business capacity necessary to discharge the duties of the position involved, and is a citizen and resident of the state, the veteran shall receive preference for appointment, employment, and promotion. For the purposes of this policy, the term "veteran" means any person who

- (1) has served on continuous federalized active military duty for a period of at least ninety days for reasons other than training the full obligation for active duty, reserve, or National Guard service in the military, or received an early discharge for a medical condition, hardship, reduction in force, or at the convenience of the military; and

- (2) has been separated or discharged from such service honorably or under honorable conditions.

An applicant wishing to be given veteran's preference must submit written verification from the military that the applicant satisfies the definition of veteran as set forth above.

Age, loss of limb, or other physical impairment which does not in fact incapacitate does not disqualify the veteran. A veteran who has a service-connected disability shall be given a preference over a nondisabled veteran.

If a veteran applies for appointment for employment under this policy, the District shall, before employing anyone to fill the position, investigate the qualifications of the applicant. If the applicant is of good moral character and can perform the duties of the position, the applicant shall be employed in the position.

All applicants for employment, including veterans, are subject to criminal background check requirements as set forth in state law.

Expense Reimbursement (Lodging, Mileage, and Meals)

The following guidelines will apply to out-of-district travel.

Within state:

- 1) Lodging must be receipted.
- 2) When a school fleet vehicle suitable for the travel purpose is not available, mileage by auto will be paid on the basis of the current state approved rate per mile traveled (distances to main cities visited are established and on file in the business office).
- 3) When a personal vehicle is taken in lieu of an available school fleet vehicle, mileage will be paid at the rate of .18 per mile traveled (distances to main cities visited are established and on file in the business office).
- 4) Air travel must be approved by the superintendent or his/her designee.
- 5) Meal allowance will be paid based on the current state approved rate.
- 6) Whenever students are provided meals and lodging at district expense, coaches and other school officials will be afforded the same meals and accommodations.

Outside state:

Expenses for travel outside of South Dakota will be paid according to current state approved rate.

Whenever students are provided meals and lodging at district expense, coaches and other school officials will be afforded the same meals and accommodations.

In-District

The following guidelines will apply to in-district travel.

Staff members who perform assigned duties in more than one school will be paid mileage at the current state approved rate. Mileage will be paid on the distance between the schools they are assigned to on a given day.

The staff member who has been authorized mileage will submit a completed voucher to the business office for payment.

In most situations, there is no meal expense allowed for in-district travel. There are occasions when the District will offer to provide a meal; i.e., "State of the Schools," "Board –Administrator work-sessions," etc. These will not be vouchered but will be directly billed and paid by the District. When the District hosts an event that requires attendance through the meal time; i.e., ESD Principals, Activities Directors, etc. .. and the meal would have been allowed had the event been in another community, the direct bill for a work session meal may be requested for approval from the superintendent in advance of the event. This must be specifically approved on a travel request, stating cause, and dictating maximum allowable dollar amount. Note: Attending regularly scheduled luncheons; i.e., regular Chamber meeting, Community Counseling meeting, etc., do not qualify for this exception.



CHANGE ORDER

PROJECT:
(Name, address)

Washington Elementary School
Addition and Renovation
1415 McClellan Drive
Huron, SD 57350

Contractor shall sign all copies
and return all copies to the
Architect. (For additional
signatures and distribution.)

TO:
(Contractor)

Welf Construction Corp.
PO Box 60
Yankton, SD 57078

ARCHITECTS PROJECT #1277

CONTRACT FOR: General

3/31/2014

You are directed to make the following changes in this Contract: RFP#63-67, 70-73

See attached back-up sheets for breakdown of change order items.

TOTAL NET INCREASE TO CONTRACT: \$10,267.00

The original Contract Sum was.....	8,093,000.00
Net change by previous Change Orders.....	136,826.00
The Contract Sum prior to this Change Order was.....	8,229,826.00
The Contract Sum will be increased by this Change Order.....	10,267.00
The new Contract Sum including this Change Order will be.....	8,240,093.00
The Contract Time will be unchanged by.....	0 days

The Date of Completion as of the date of this Change Order therefore is:

It is hereby agreed that the provisions of the contract shall not be otherwise changed or affected by the provisions of this change order.

Recommended by:

Accepted by:

Approved by:

Koch Hazard Architects

Welf Construction Corporation

Huron School District 2-2

431 N. Phillips Avenue, Suite 200

PO Box 60

150 5th Street SE

Sioux Falls, SD 57104

Yankton, SD 57078

Huron, SD 57350

By: 
Jeffrey A. Hazard, AIA

By: 

By:

Date: August 5, 2015

Date: 8-11-15

Date

DATE OF ISSUANCE: 8/5/15

CHANGE ORDER NO. G-4



Date: 08/04/15
 Project: Washington Elementary School Addition & Renovation/ 1277A
 Subject: Architect's Proposal/Change Order Log
 To: Welfl Construction Company

	Request for <u>Proposal</u>	Proposal Rec'd	Revised Proposal	A/E Recommendation to <u>Owner</u>	Owner <u>Approval</u>	CO <u>Initiated</u>
<u>Proposals/CO's in Process</u> (Items incorporated in a change order, not approved or voided have been deleted from the list.)						
Allowances: See RFP 016						
063. Modify doors 182A/B	5/7/15	<u>5/28/15</u> -559.00 0 days		6/3/15 -559.00 days	6/3/15 -559.00 days	<u>G-4 8/5/15</u> -559.00 0 days
064. Replace Gypsum on Stage Wall	5/21/15	<u>6/15/15</u> 1,719.00 0 days		<u>6/17/15</u> 1,719.00 0 days	<u>6/17/15</u> 1,719.00 0 days	<u>G-4 8/5/15</u> 1,719.00 0 days
065. Modify Commons corridor ceiling	6/4/15	<u>6/17/15</u> 1,365.00 0 days		<u>6/18/15</u> 1,365.00 0 days	<u>6/18/15</u> 1,365.00 0 days	<u>G-4 8/5/15</u> 1,365.00 0 days
066. Modify cloud detail	6/4/15	<u>6/17/15</u> -420.00 0 days		<u>6/18/15</u> -420.00 0 days	<u>6/18/15</u> -420.00 0 days	<u>G-4 8/5/15</u> -420.00 0 days
067. Deduct for sound system	6/4/15	<u>6/15/15</u> -485.00 0 days		<u>6/17/15</u> -485.00 0 days	<u>6/17/15</u> -485.00 0 days	<u>G-4 8/5/15</u> -485.00 0 days
068. Room 187 Exsting Louver Wall Infill	6/4/15	<u>6/15/15</u> 524.00 0 days		Rejected		
069R. Music 136 - Install ACP ceiling	6/9/15	<u>6/17/15</u> 4,985.00 0 days		Rejected		
070. LED lights in existing Commons	6/24/15	<u>7/1/15</u> 4,690.00 0 days		<u>7/6/15</u> 4,690.00 0 days	<u>7/8/15</u> 4,690.00 0 days	<u>G-4 8/5/15</u> 4,690.00 0 days

071. Add CATV amplifiers	6/30/15	<u>7/8/15</u> 2,563.00 0 days	<u>7/9/15</u> 2,563.00 0 days	<u>7/9/15</u> 2,563.00 0 days	<u>G-4 8/5/15</u> 2,563.00 0 days
072. Commons Painting	7/13/15	<u>7/23/15</u> 1,564.00 0 days	<u>7/23/15</u> 1,564.00 0 days	<u>7/24/15</u> 1,564.00 0 days	<u>G-4 8/5/15</u> 1,564.00 0 days
073. Delete ceiling tile in Room 106	7/22/15	<u>7/27/15</u> -170.00 0 days	<u>7/27/15</u> -170.00 0 days	<u>7/27/15</u> -170.00 0 days	<u>G-4 8/5/15</u> -170.00 0 days

G-4 \$10,267.00

Sincerely,

KOCH HAZARD ARCHITECTS

Tony Taylor, Associate Principal

Koch Hazard Log



KOCH HAZARD
ARCHITECTS

REQUEST FOR PROPOSAL (RFP)

RFP 063

DATE: 7 May 2015

TO: Welf Construction Company

PROJECT: Washington Elementary School Addition and Renovation/#1277A
Huron School District 2-2
Huron, South Dakota

Owner Requested: _____ Contractor Requested: _____ Unforeseen Conditions _____ Design Issue _____

Proposal Requests are for information only. Do not consider them instructions either to stop work in progress or to execute the proposed change.

Please submit an itemized cost breakdown, in accordance with the General Conditions, for changes in contract sum and contract time, resulting from the following proposed modification(s) to the Contract Documents.

PLEASE SUBMIT PROPOSAL WITHIN TEN (10) DAYS OR LESS

DESCRIPTION OF WORK:

Provide an itemized proposal for the following:

1. Add additional CMU to the wall to the west of Vestibule 182 and modify current frame type 11 – remove sidelights and transom. Use current scheduled doors and hardware.
2. Modify current frame type 10 – remove east sidelight and provide a larger sidelight on the west side. Use current scheduled doors and hardware.
3. See attached drawings.

ARCHITECT - KOCH HAZARD

Chris Brockevelt – Project Technician

REPRESENTATIVE

CC: Kelly Christopherson, Business Manager, Huron School District
Norm deWit, ACEI
Brad Shoup, ACEI
Randy Hoscheid, Pierce & Harris Engineering
Rob Maher, SEA
Tony Taylor, Koch Hazard Architects
Koch Hazard Architects log

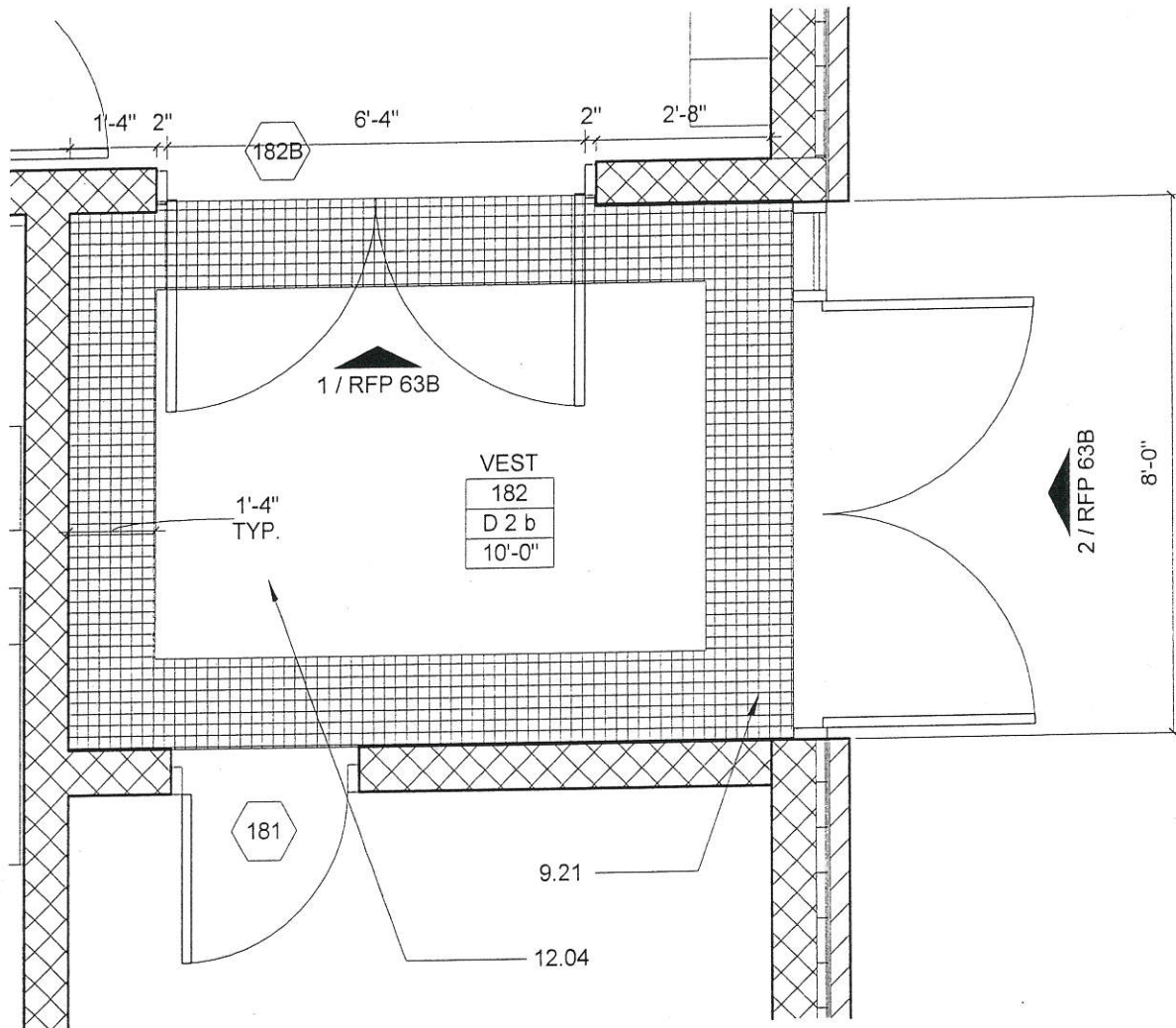

VESTIBULE 182 FLOOR PLAN - AREA D

3/8" = 1'-0"



K O C H H A Z A R D
A R C H I T E C T S

431 North Phillips 200 Sioux Falls, SD 57104 T: 605-336-3718 F: 605-336-0438 W: kochhazard.com

VEST. 182 - MODIFIED DOORS FLOOR PLAN

Huron School District
Washington 4 - 5 Center Addition & Renovation

Huron, SD

PROJECT NO:
1277A

DRAWN BY:
CJB

DATE:
05/07/15

COPYRIGHT:
2014

RFP
63A

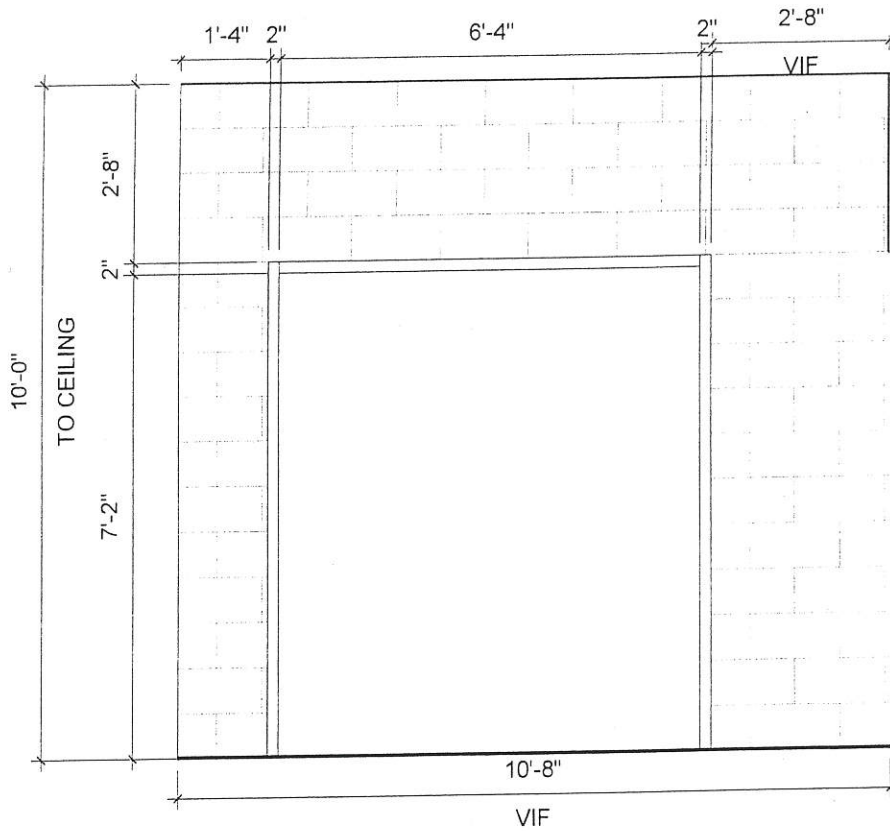

① MODIFIED DOOR 182B
 3/8" = 1'-0"

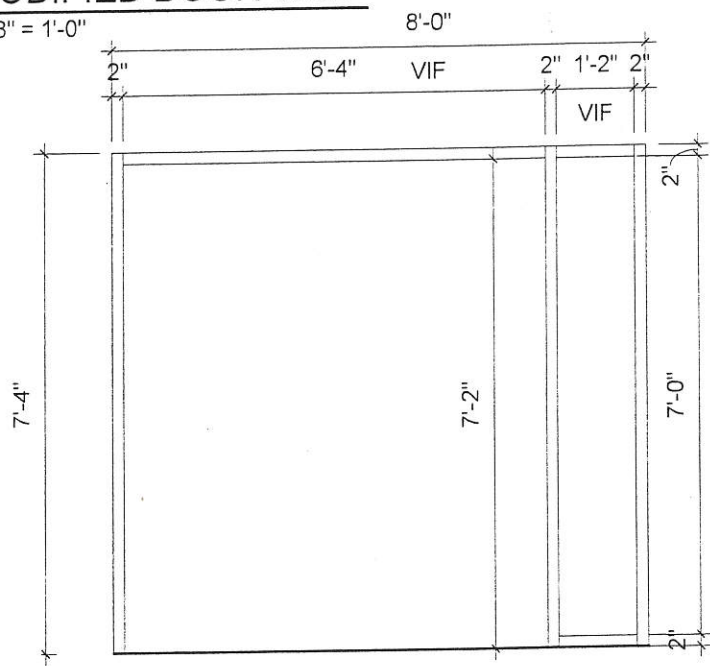

② MODIFIED DOOR 182A
 3/8" = 1'-0"



KOCH HAZARD
 ARCHITECTS

431 North Phillips 200 Sioux Falls, SD 57104 T: 605-336-3718 F: 605-336-0438 W: kochhazard.com

VEST. 182 - MODIFIED DOOR ELEVATIONS
 Huron School District
 Washington 4 - 5 Center Addition & Renovation
 Huron, SD

PROJECT NO.:
 1277A

DRAWN BY:
 CJB

DATE:
 05/07/15

COPYRIGHT:
 2014

RFP
63B



RFP

To: Koch Hazard
431 N. Phillips
Suite 200
Sioux Falls, SD 57104
Ph: (605)336-3718 Fax: (605)336-0438

Number: 63
Date: 5/28/15
Job: 34-345 Huron- Washington Elem School
Phone:

Description: Vestibule 182 modifications.

We are pleased to offer the following specifications and pricing to make the following changes:

Add additional CMU to the wall to the West of Vestibule 182 and modify current frame type 11 - remove sidelights and transom. Use current scheduled doors and hardware.

Modify current frame type 10 - remove East sidelight and provide a larger sidelight on the West side. Use current scheduled doors and hardware.

The total amount to provide this work is \$-559.00

The schedule is not affected by this change.

If you have any questions, please contact me at .

Submitted by: Kevin Bender

Approved by: _____
Date: _____

Cc:

INTERSTATE Glass & Door, Inc.

PROPOSAL

P. O. Box 727 • 701 S. Burr • Mitchell, SD 57301 • 605-996-2720 • FAX 605-996-0646

NAME/ADDRESS
WELFL CONSTRUCTION CO. PO BOX 60 YANKTON, S.D. 57078

DATE
5/27/2015

AMOUNT
ADDENDA

SALES TAX	EXCISE TAX	LOCATION	Project
INCLUDED	NOT INCLUDED	HURON, S.D.	RFP 063

DESCRIPTION
<p>WASHINGTON ELEMENTARY</p> <p>REF: RFP 063</p> <p>DEDUCT: \$547.00 FROM OUR CONTRACT FOR THE ABOVE RFP TO ELIMINATE THE SIDELITES AND TRANSOM ON FRAME TYPE 11 AND ELIMINATE THE TRANSOM FROM FRAME TYPE 10.</p>

	TOTAL	\$0.00
--	--------------	--------

ACCEPTED BY: _____
CONTRACTOR: _____

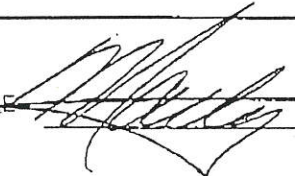
SIGNATURE  _____

34-345 Huron- Washington Elem School

RFP - 63
Vestibule 182 modifications.

Welfl Construction Corporation

Print Date 5/28/2015

<u>Number</u>	<u>Date</u>	<u>Description</u>	<u>Labor</u>	<u>Material</u>	<u>Sub</u>	<u>Total</u>
63	5/28/15	Vestibule 182 modifications.				
		Glazing			-547.00	-547.00
		Sales Tax				0.00
		Payroll Tax				0.00
		OH on Sub Work				0.00
		OH on WCC Work				0.00
		Bond & Builders Risk				0.00
		Excise Tax				-11.71
		Rounding				-0.29

Total Price RFP - 63

\$-559.00

From: willi1020.jw@gmail.com
Sent: Thursday, May 14, 2015 9:12 AM
To: Kevin Bender
Subject: Re: Washington Elementary RFP # 63

Kevin,

RFP # 63

No change.

Thanks,
Williams Masonry
Joe Williams

Sent from Windows Mail

From: Kevin Bender
Sent: Tuesday, May 12, 2015 8:40 AM
To: willi1020.jw@gmail.com, marty@interstateglassanddoor.com
Cc: Archive rule

Joe/Marty,
Please see the attached RFP and get me your revised prices. Call with questions.
Thanks,

Kevin Bender
Welfl Construction Corp.
800 West 23rd St.
P.O. Box 60
Yankton, SD 57078
605-665-3258
605-665-9384 fax



KOCH - HAZARD
ARCHITECTS

REQUEST FOR PROPOSAL (RFP)

RFP 064

DATE: 20 May 2015

TO: Welf Construction Company

PROJECT: Washington Elementary School Addition and Renovation/#1277A
Huron School District 2-2
Huron, South Dakota

Owner Requested: _____ Contractor Requested: x Unforeseen Conditions _____ Design Issue _____

Proposal Requests are for information only. Do not consider them instructions either to stop work in progress or to execute the proposed change.

Please submit an itemized cost breakdown, in accordance with the General Conditions, for changes in contract sum and contract time, resulting from the following proposed modification(s) to the Contract Documents.

PLEASE SUBMIT PROPOSAL WITHIN TEN (10) DAYS OR LESS

DESCRIPTION OF WORK:

1. Provide an itemized proposal for removing existing gypsum on the lower 8' of the Stage wall and replacing with new gypsum. Match the lower texture to the existing texture.

ARCHITECT - KOCH HAZARD

Chris Brockevelt, Project Developer

REPRESENTATIVE

CC: Kelly Christopherson, Business Manager, Huron School District
Norm deWit, ACEI
Brad Shoup, ACEI
Randy Hoscheid, Pierce & Harris Engineering
Rob Maher, SEA
Chris Brockevelt, Koch Hazard Architects
Koch Hazard Architects log



REPLACE LOWER GYPSUM TO STAGE WALL

1/4" = 1'-0"

VIF

MATCH TEXTURE TO EXISTING ABOVE



K O C H H A Z A R D
A R C H I T E C T S

431 North Phillips 200 Sioux Falls, SD 57104 T: 605-336-3718 F: 605-336-0438 W: kochhazard.com

GYPSUM TO STAGE WALL

Huron School District
Washington 4 - 5 Center Addition & Renovation
Huron, SD

PROJECT NO:
1277A

DRAWN BY:
CJB

DATE:
05/20/15

COPYRIGHT:
2014

RFP
64



RFP

To: Koch Hazard
431 N. Phillips
Suite 200
Sioux Falls, SD 57104
Ph: (605)336-3718 Fax: (605)336-0438

Number: 64
Date: 6/9/15
Job: 34-345 Huron- Washington Elem School
Phone:

Description: Replace lower portion of gypsum on stage wall.

We are pleased to offer the following specifications and pricing to make the following changes:
Replace the lower 8' of gypsum board on the stage wall and replace with new gypsum. Match texture of new gypsum to higher gypsum.

The total amount to provide this work is \$1,719.00

The schedule is not affected by this change.

If you have any questions, please contact me at .

Submitted by: Kevin Bender

Approved by: _____
Date: _____

Cc:

34-345 Huron- Washington Elem School

RFP - 64

Replace lower portion of gypsum on stage wall.

Welfl Construction Corporation

Print Date 6/15/2015

<u>Number</u>	<u>Date</u>	<u>Description</u>	<u>Labor</u>	<u>Material</u>	<u>Sub</u>	<u>Total</u>
64	6/9/15	Replace lower portion of gypsum on stage wall.				
		Gypsum Board Assemblies		50.00	1,520.00	1,570.00
		Sales Tax				3.00
		Payroll Tax				0.00
		OH on Sub Work				91.20
		OH on WCC Work				4.00
		Bond & Builders Risk				14.46
		Excise Tax				36.01
		Rounding				0.33
					Total Price RFP - 64	\$1,719.00



4875 7th Street
 Sioux Falls, SD 57105
 Telephone: 605-339-0277
 Fax: 605-339-1300
 E-mail: info@ddw.com

Date: June 9, 2015
 INVOICE # 112

To: Welzl Construction

Salesperson	Job	Payment Terms	Due Date
	Washington Elementary		
Qty	Description	Unit Price	Price Total
	RFP 68- Tear off gypsum in existing gym replace match texture		\$1520.00
	RFP 65- Modify Ceilings		\$1250.00
	Laundry Room Solfit and Ceiling		\$1025.00
Total			\$3795.00

Thank you for your business!



K O C H H A Z A R D
A R C H I T E C T S

REQUEST FOR PROPOSAL (RFP)

RFP 065

DATE: 2 June 2015

TO: Welfl Construction Company

PROJECT: Washington Elementary School Addition and Renovation/#1277A
Huron School District 2-2
Huron, South Dakota

Owner Requested: _____ Contractor Requested: Unforeseen Conditions _____ Design Issue _____

Proposal Requests are for information only. Do not consider them instructions either to stop work in progress or to execute the proposed change.

Please submit an itemized cost breakdown, in accordance with the General Conditions, for changes in contract sum and contract time, resulting from the following proposed modification(s) to the Contract Documents.

PLEASE SUBMIT PROPOSAL WITHIN TEN (10) DAYS OR LESS

DESCRIPTION OF WORK:

Provide an itemized proposal for the following:

1. Lower the ceiling between Doors 160B/C and Grid Line D in Corridor 192 to 7'-8" in lieu of 8'-0".
2. Rotate lighting 90 degrees and place between new joists.
3. Replace Detail 1/A3.6 on page A3.4 with ACP that continues from Commons 160A to Grid Line D at 8'-8".
4. Install bulkheads around lowered ceiling. Columns shall be built into new bulkheads, not the ACP ceiling.
5. See attached drawings.

ARCHITECT - KOCH HAZARD

Chris Brockevelt, Project Developer

REPRESENTATIVE

CC: Kelly Christopherson, Business Manager, Huron School District
Norm deWit, ACEI
Brad Shoup, ACEI
Randy Hoscheid, Pierce & Harris Engineering
Rob Maher, SEA
Chris Brockevelt, Koch Hazard Architects
Koch Hazard Architects log

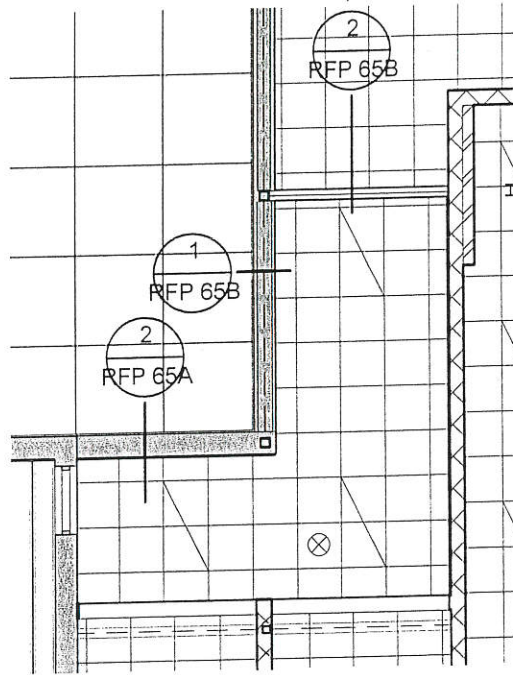

① **FIRST FLOOR - AREA C OPTION**
 1/8" = 1'-0"

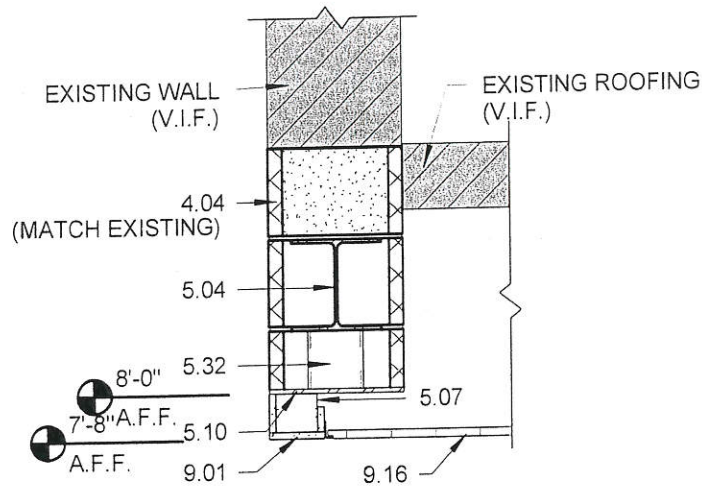

② **BULKHEAD DETAIL**
 3/4" = 1'-0"



K O C H H A Z A R D
 A R C H I T E C T S

431 North Phillips 200 Sioux Falls, SD 57104 T 605-336-3718 F 605-336-0438 W: kochhazard.com

Unnamed
 Huron School District
 Washington 4 - 5 Center Addition & Renovation
 Huron, SD

PROJECT NO.:
 1277A

DRAWN BY:
 Author

DATE:
 05/21/15

COPYRIGHT:
 2012

RFP
65A

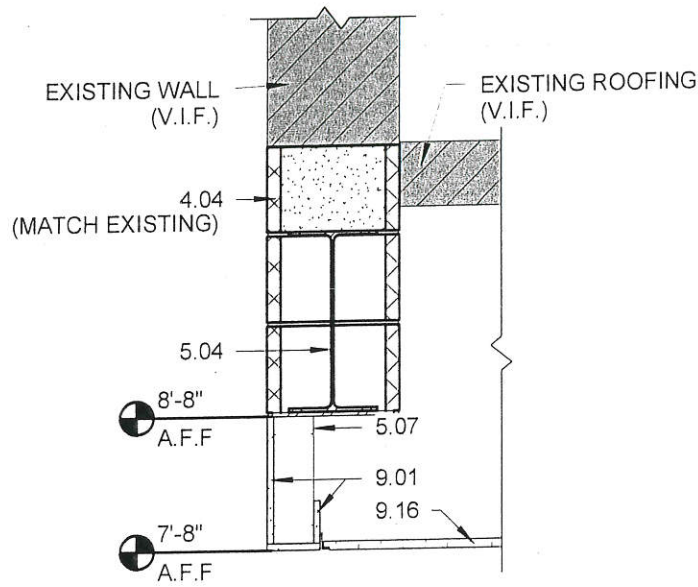

① **BULKHEAD DETAIL**
3/4" = 1'-0"

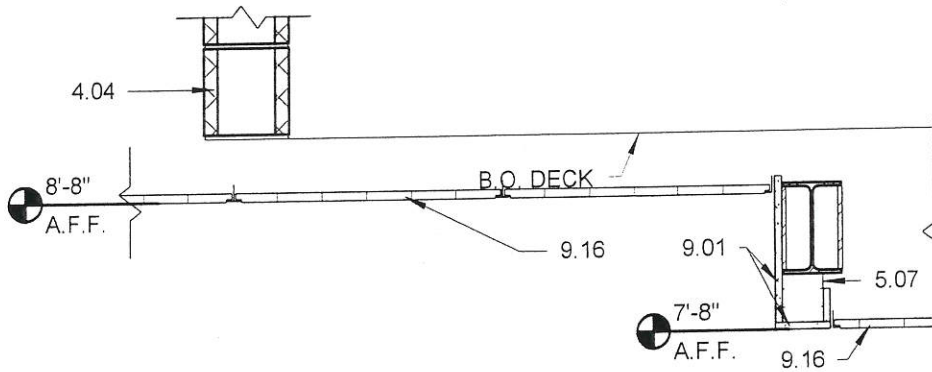

② **BULKHEAD DETAIL**
3/4" = 1'-0"



KOCH HAZARD
ARCHITECTS

431 North Phillips 200 Sioux Falls, SD 57104 T: 605-336-3718 F: 605-336-0438 W: kochhazard.com

Unnamed
Huron School District
Washington 4 - 5 Center Addition & Renovation
Huron, SD

PROJECT NO.:
1277A

DRAWN BY:
Author

DATE:
05/21/15

COPYRIGHT:
2012

RFP
65B



RFP

To: Koch Hazard
431 N. Phillips
Suite 200
Sioux Falls, SD 57104
Ph: (605)336-3718 Fax: (605)336-0438

Number: 65
Date: 6/17/15
Job: 34-345 Huron- Washington Elem School
Phone:

Description: Common 160 ceiling bulkheads.

We are pleased to offer the following specifications and pricing to make the following changes:
Adjust ceiling heights per narrative on RFP # 65 dated June 2, 2015.

The total amount to provide this work is \$1,365.00

The schedule is not affected by this change.

If you have any questions, please contact me at .

Submitted by: Kevin Bender

Approved by: _____
Date: _____

Cc:

34-345 Huron- Washington Elem School

RFP - 65
Common 160 ceiling bulkheads.

Print Date 6/17/2015

Welfl Construction Corporation

<u>Number</u>	<u>Date</u>	<u>Description</u>	<u>Labor</u>	<u>Material</u>	<u>Sub</u>	<u>Total</u>
65	6/17/15	Common 160 ceiling bulkheads.			1,250.00	1,250.00
		Gypsum Board Assemblies				0.00
		Sales Tax				0.00
		Payroll Tax				75.00
		OH on Sub Work				0.00
		OH on WCC Work				11.49
		Bond & Builders Risk				28.60
		Excise Tax				-0.09
		Rounding				

Total Price RFP - 65

\$1,365.00



187 E. 24th Street
 Sioux Falls, SD 57104
 Telephone: 605-337-1177
 Fax: 605-337-4008

Date: June 9, 2015
 INVOICE # 112

To: Welfi Construction

Salesperson Job Payment Terms Due Date
 Washington Elementary

Qty	Description	Unit Price	Price Total
	RFP 68- Tear off gypsum in existing gym replace match texture		\$1520.00
	RFP 65- Modify Ceilings		\$1250.00
	Lauriary Room Soffit and Ceiling		\$1025.00

Total \$3795.00

Thank you for your business!



K O C H H A Z A R D
A R C H I T E C T S

REQUEST FOR PROPOSAL (RFP)

RFP 066

DATE: 3 June 2015

TO: Welfl Construction Company

PROJECT: Washington Elementary School Addition and Renovation/#1277A
Huron School District 2-2
Huron, South Dakota

Owner Requested: _____ Contractor Requested: Unforeseen Conditions _____ Design Issue _____

Proposal Requests are for information only. Do not consider them instructions either to stop work in progress or to execute the proposed change.

Please submit an itemized cost breakdown, in accordance with the General Conditions, for changes in contract sum and contract time, resulting from the following proposed modification(s) to the Contract Documents.

PLEASE SUBMIT PROPOSAL WITHIN TEN (10) DAYS OR LESS

DESCRIPTION OF WORK:

Provide an itemized proposal for the following:

1. Revise cloud detail 2/A3.6.
2. See attached drawing.

ARCHITECT - KOCH HAZARD

Chris Brockevelt, Project Developer

REPRESENTATIVE

CC: Kelly Christopherson, Business Manager, Huron School District
Norm deWit, ACEI
Brad Shoup, ACEI
Randy Hoscheid, Pierce & Harris Engineering
Rob Maher, SEA
Chris Brockevelt, Koch Hazard Architects
Koch Hazard Architects log

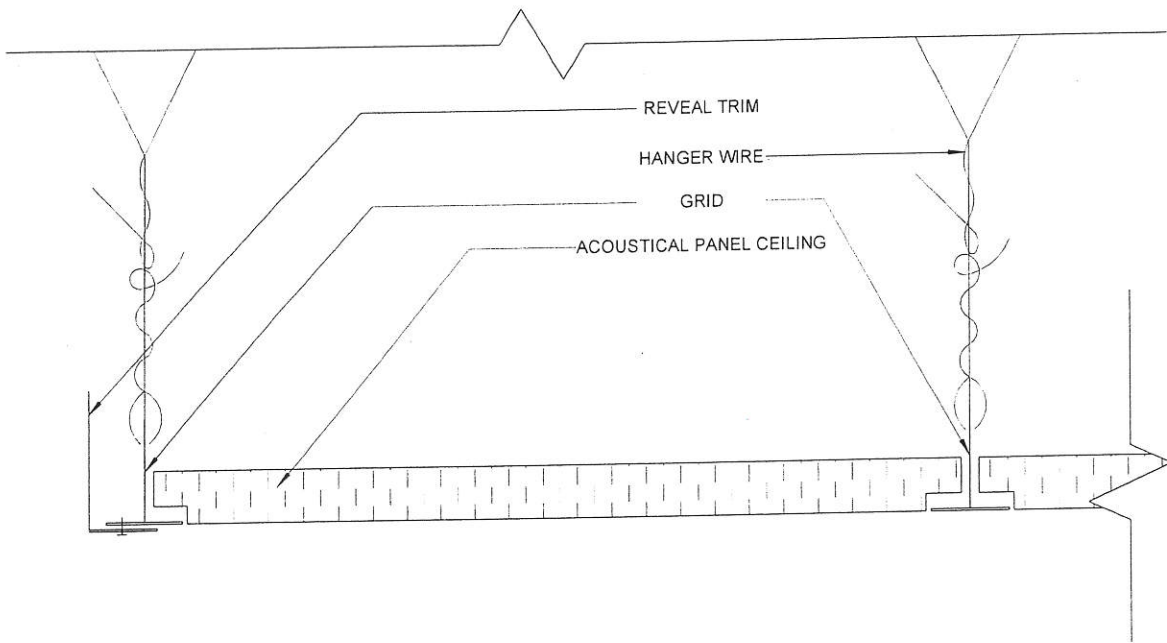

CEILING CLOUD DETAIL
6" = 1'-0"



K O C H H A Z A R D
A R C H I T E C T S

431 North Phillips 200 Sioux Falls, SD 57104 T: 605-336-3718 F: 605-336-0438 W: kochhazard.com

CEILING CLOUD MODIFICATION

Huron School District
Washington 4 - 5 Center Addition & Renovation
Huron, SD

PROJECT NO.:
1277A

DRAWN BY:
CJB

DATE:
06/3/15

COPYRIGHT:
2014

RFP
66



RFP

To: Koch Hazard
431 N. Phillips
Suite 200
Sioux Falls, SD 57104
Ph: (605)336-3718 Fax: (605)336-0438

Number: 66
Date: 6/17/15
Job: 34-345 Huron- Washington Elem School
Phone:

Description: Revised acoustical cloud detail.

We are pleased to offer the following specifications and pricing to make the following changes:

Revise cloud detail 2/A3.6

The total amount to provide this work is \$-420.00

The schedule is not affected by this change.

If you have any questions, please contact me at .

Submitted by: Kevin Bender

Approved by: _____
Date: _____

Cc:

34-345 Huron- Washington Elem School

RFP - 66
Revised acoustical cloud detail.

Welfl Construction Corporation

Print Date 6/17/2015

<u>Number</u>	<u>Date</u>	<u>Description</u>	<u>Labor</u>	<u>Material</u>	<u>Sub</u>	<u>Total</u>
66	6/17/15	Revised acoustical cloud detail.				
		<i>Gypsum Board Assemblies</i>			-2,560.00	-2,560.00
		<i>Acoustical Tile Ceilings</i>			2,152.00	2,152.00
		<i>Sales Tax</i>				0.00
		<i>Payroll Tax</i>				0.00
		<i>OH on Sub Work</i>				0.00
		<i>OH on WCC Work</i>				0.00
		<i>Bond & Builders Risk</i>				-3.54
		<i>Excise Tax</i>				-8.81
		<i>Rounding</i>				0.35
					Total Price RFP - 66	\$-420.00

Dakota Acoustical Tile Change Order

JOB NAME	WASHINGTON ELEM		
LOCATION	HURON, SD		
CHANGE NUMBER	RFP #66		
DESCRIPTION OF CHANGE	REVISE CLOUD DETAIL 2/A3.6		
ATTN: KEVIN BENDER			
GENERAL: WELFL CONSTRUCTION			
LABOR	MAN HOURS	RATE	EXTENSION
CARPENTER ACOUST TILE CLGS	34	\$30.00	\$1,020.00
CARPENTER GYP. BD./FRAMING		\$0.00	\$0.00
CARPENTER EIFS		\$0.00	\$0.00
CARPENTER SOFFIT WORK		\$0.00	\$0.00
PAPER		\$0.00	\$0.00
SUBTOTAL			\$0.00
FUI/SUI		8.50%	\$86.70
WORKER'S COMP.		11.00%	\$112.20
FICA		7.65%	\$78.03
			\$0.00
SUBTOTAL LABOR			\$1,296.93
PER DIEM	8	\$30.00	\$240.00
MATERIALS	QUANTITY	UNIT COST	EXTENSION
ADD 1X2 WALL CHANNEL	512	\$0.480	\$245.76
ADDITIONAL MAINS	256	\$0.420	\$107.52
MISC ATTACHMENTS	512	\$0.150	\$76.80
	0	\$0.000	\$0.00
	0	\$0.000	\$0.00
			\$0.00
	0	\$0.000	\$0.00
		\$0.000	\$0.00
		\$0.000	\$0.00
		\$0.000	\$0.00
		\$0.000	\$0.00
		\$0.000	\$0.00
		\$0.000	\$0.00
		\$0.000	\$0.00
		\$0.000	\$0.00
		\$0.000	\$0.00
		\$0.000	\$0.00
		\$0.000	\$0.00
		\$0.000	\$0.00
		\$0.000	\$0.00
SUBTOTAL MATERIALS			\$430.08
STATE & LOCAL TAXES		6.000%	\$25.90
TOTAL MATERIALS			\$455.88
TOTAL LABOR			\$1,536.93
SUBTOTAL MATERIALS & LABOR			\$1,992.81
OVERHEAD		8.00%	\$159.43
SUB-TOTAL			\$2,152.24
FEE		0.00%	\$0.00
TOTAL QUOTE (ROUND OFF)			\$2,152



Date: June 16, 2015
INVOICE # 113

To: Well Construction

Salesperson

Job

Payment Terms

Due Date

Washington Elementary

Qty

Description

Unit Price

Price Total

RFP 66- CREDIT

\$2560.00

Total Credit

\$2560.00

Thank you for your business!



REQUEST FOR PROPOSAL (RFP)

RFP 067

DATE: 04 June 2015

TO: Welf Construction Company

PROJECT: Washington Elementary School Addition and Renovation/#1277A
Huron School District 2-2
Huron, South Dakota

Owner Requested: Contractor Requested: _____ Unforeseen Conditions _____ Design Issue _____

Proposal Requests are for information only. Do not consider them instructions either to stop work in progress or to execute the proposed change.

Please submit an itemized cost breakdown, in accordance with the General Conditions, for changes in contract sum and contract time, resulting from the following proposed modification(s) to the Contract Documents.

PLEASE SUBMIT PROPOSAL WITHIN TEN (10) DAYS OR LESS

DESCRIPTION OF WORK:

1. Reference electrical plan sheets E2.1 and E3.6:
2. Provide credit not to re-install the existing commons sound re-inforcement system equipment.

ARCHITECT - KOCH HAZARD

Chris Brockvelt – Project Technician

REPRESENTATIVE

CC: Kelly Christopherson, Business Manager, Huron School District
Norm deWit, ACEI
Brad Shoup, ACEI
Randy Hoscheid, Pierce & Harris Engineering
Rob Maher, SEA
Tony Taylor, Koch Hazard Architects
Koch Hazard Architects log



RFP

To: Koch Hazard
431 N. Phillips
Suite 200
Sioux Falls, SD 57104
Ph: (605)336-3718 Fax: (605)336-0438

Number: 67
Date: 6/15/15
Job: 34-345 Huron- Washington Elem School
Phone:

Description: Existing commons sound system.

We are pleased to offer the following specifications and pricing to make the following changes:
Provide credit for not re-installing the existing commons sound re-inforcement system equipment.

The total amount to provide this work is \$-485.00

The schedule is not affected by this change.

If you have any questions, please contact me at .

Submitted by: Kevin Bender

Approved by: _____
Date: _____

Cc:

34-345 Huron- Washington Elem School

RFP - 67
Existing commons sound system.

Welfl Construction Corporation

Print Date 6/15/2015

<u>Number</u>	<u>Date</u>	<u>Description</u>	<u>Labor</u>	<u>Material</u>	<u>Sub</u>	<u>Total</u>
67	6/15/15	Existing commons sound system.				
		Electrical			-471.00	-471.00
		Sales Tax				0.00
		Payroll Tax				0.00
		OH on Sub Work				0.00
		OH on WCC Work				0.00
		Bond & Builders Risk				-4.08
		Excise Tax				-10.17
		Rounding				0.25
					Total Price RFP - 67	\$-485.00



Muth Electric Inc.



307 Dakota Avenue North • P.O. Box 1437 • Huron, SD 57350
PHONE (605) 352-8579 • FAX (605) 352-0939
www.muthelectric.com

June 12, 2015

Welfl Construction
Attn: Kevin Bender
800 West 23rd St.
Yankton, SD 57078

RE: Washington School
RFP 067
Huron, SD

Dear Kevin,

Our price for the electrical work for RFP 067 is:

Delete: \$471.00

If you have any questions or comments, please feel free to call me at (605) 352-8579.
We appreciate the opportunity to work with you.

MUTH ELECTRIC, INC.

Tom Sandve
Division Manager

Acceptance of Proposal - The above prices, specifications and conditions are satisfactory and are hereby accepted. You are authorized to do the work as specified by the receiving of this faxed notice signature from you.

Date of Acceptance: _____

Signature: _____

"Professional Answers For All Your Electrical Needs"

CORPORATE
(605) 996-3983

MITCHELL, SD
(605) 996-7300

SIOUX FALLS, SD
(605) 338-6586

RAPID CITY, SD
(605) 341-3554

WATERTOWN, SD
(605) 882-2680

ABERDEEN, SD
(605) 226-8424

BROOKINGS, SD
(605) 692-0800

OMAHA, NE
(402) 551-7780

WILLISTON, ND
(701) 577-7300

Muth Electric, Inc.

Bid Summary Sheet

Estimate #: 32091 Location: Huron

Muth Job Number: 5258

Customer: Welfl Construction

Address 1451 McClellan Drive

Description: Washington School - RFP067

Estimated By: Tom S.

Checked By: Tom S.

Estimate Date: 6/11/2015

Revision Date:

Submission Date

Change Order
Status

Approved

Proposed

GC C/O #

Executed

Void

Muth C/O #:

Approval Date

Coordination Time	Hours
Foreman Time:	0.00
Travel Time:	0.00
Miscellaneous Time:	0.00
Total (A)	0.00

	Material Cost	Labor Hours
Total from Estimate Item Detail	(\$41.98)	-6.56
Misc Material and Labor: 3.00 %	(\$1.26)	-0.20
Coordination Time		0.00
TOTAL MATERIAL (C) AND LABOR (D)	(\$43.23)	-6.75
-6.75 Regular Labor Hours @ \$36.00		(\$243.06)

Job Expense		
Tools, Scaffolds - 10 % of Labor Total		(\$32.08)
Safety- 6 % of Labor Total		(\$19.25)
Clean Up - 4 % of Labor Total		(\$12.83)
Warranty - 3 % of Labor Total		(\$9.63)
Temporary Power		\$0.00
Cutting, Patching, Painting		\$0.00
Use/Sales Tax 6.00 %		(\$2.59)
Inspection and Permit Fees		\$0.00
Field Incentive \$0.50 per hour		(\$3.38)
Material Storage		\$0.00
Freight		\$0.00
Mileage 0 Miles @ \$0.80 per Mile		\$0.00
Trenching 0 ft. @ 0 per ft.:		\$0.00
Plowing 0 ft. @ 0 per ft.:		\$0.00
Backhoe 0 ft. @ 0 per ft.		\$0.00
Equipment/Tools		\$0.00
Muth Equipment 0 Units: x \$0.00 Rate		\$0.00
Muth Equipment #2 0 Units: x \$0.00 Rate		\$0.00
Meals/ Lodging		\$0.00
Total Job Expenses (B)		(\$79.76)

0.00 Overtime Hours @ \$0.00	\$0.00
Labor Burden 32%	(\$77.78)
Labor Total	(\$320.84)
Subcontracts	\$0.00
Job Expense (B)	(\$79.76)
Material Cost	(\$43.23)
Total Direct Cost	(\$443.84)
Overhead 3 %	(\$13.32)
Sub Total	(\$457.16)
Profit 3%	(\$13.71)
Sub Total	(\$470.87)
SD Contractors Excise Tax 0 %	\$0.00
Sub Total	(\$470.87)
Performance Bond	\$0.00
Total	(\$470.87)

SubContractor Report

Subcontractor Name:	Phase:	Amount:
None	0	\$0.00
		\$0.00

Muth Electric - Estimate Detail Report

Muth Job Number: 5258
Estimate#: 32091 Estimated By: Tom S.
Customer: Welf Construction
Job Desc: Washington School - RFP067
Location: Huron

Muth Item #	Description	Quantity	Labor Units	Labor Units Extension
	SPEAKER - FBO	-2	1.1500	-2.30
	CABLE	-150	0.0092	-1.38
	SOUND EQUIPME	-1	2.3000	-2.30
	ANCHORS	-1	0.5750	-0.57
	Totals			-6.55

#####



KOCH HAZARD
ARCHITECTS

REQUEST FOR PROPOSAL (RFP)

RFP 070

DATE: 24 June 2015

TO: Welf Construction Company

PROJECT: Washington Elementary School Addition and Renovation/#1277A
Huron School District 2-2
Huron, South Dakota

Owner Requested: Contractor Requested: _____ Unforeseen Conditions _____ Design Issue _____

Proposal Requests are for information only. Do not consider them instructions either to stop work in progress or to execute the proposed change.

Please submit an itemized cost breakdown, in accordance with the General Conditions, for changes in contract sum and contract time, resulting from the following proposed modification(s) to the Contract Documents.

PLEASE SUBMIT PROPOSAL WITHIN TEN (10) DAYS OR LESS

DESCRIPTION OF WORK:

Provide an itemized proposal for the following:

1. Provide an itemized proposal for new LED light fixtures in existing Commons;
2. Reference electrical plan sheet E3.5, room 160: Retrofit 8 existing type "XG" and 1 existing type "XG1" luminaires with GPE 600750 LED lamp.
3. See attached.

ARCHITECT - KOCH HAZARD

Chris Brockevelt, Project Developer

REPRESENTATIVE

CC: Kelly Christopherson, Business Manager, Huron School District
Norm deWit, ACEI
Brad Shoup, ACEI
Randy Hoscheid, Pierce & Harris Engineering
Rob Maher, SEA
Chris Brockevelt, Koch Hazard Architects
Koch Hazard Architects log

LED Replacement Lamps for High/Low Bay HID Applications



PROUDLY MADE IN THE USA

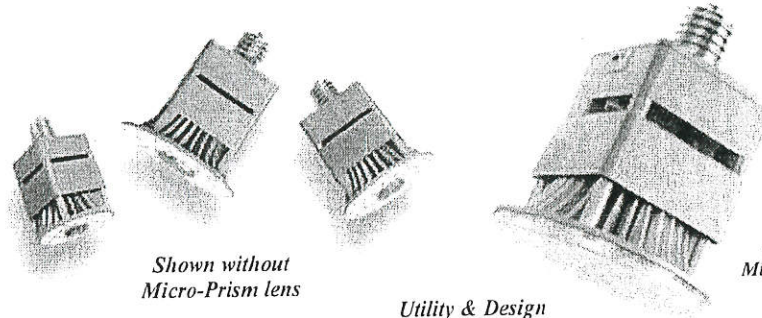

Shown without
Micro-Prism lens

Utility & Design
Patents Pending

Shown with
Micro-Prism lens

- New In-line high-efficiency power supply with PFC replaces energy-wasting ballast
- Simply bypass conventional ballast - Remove/Recycle for additional ROI
- Direct Replacement for HID Bulbs and is 0-10 VDC dimmable
- Fits all conventional high-bay luminaire fixtures with no modification to fixture
- Retain current fixtures – No need for costly replacements (UL 1598C - LED Conversion)
- Selectable Output Level on each LED Hi-Bay to customize lighting levels
- Compatible with line voltages up to 277 VAC with no modification (50/60 Hz)
- Active Thermal Management circuitry ensures long operating life
- Thermal Safety Protection Fuse

Indoor Commercial/Industrial/Institutional Applications:

- Warehouses
- Retail Box Stores
- Sports Complexes
- Parking Garages
- Fueling Stations
- Large Auditoriums
- Industrial Buildings
- Gymnasiums
- Correction Facilities

Available in Standard 4500K - Best Combination of Brightness for Security and Spectral Content for Accurate Color Representation. *Other Color Temps Available**

70 - 100 Lumens per Watt (CREE XLamp, XM-L2)
(Depending on Light Level Output setting)

75 - 80 CRI*

UL/CSA/CE • LM79, LM80, TM21

LDL & Bonneville Power Administration (BPA)**

HI-Bay Model #	# LED's	Selectable Lumen Range	System Watts ¹	Compare to HID System Watts ²
GPE-325400	20	Adjustable to 9,706 max	14-148 14w=0 light	up to 450
GPE-450550	30	Adjustable to 15,428 max	14-221 14w=0 light	up to 600
GPE-600750	42	Adjustable to 21,714 max	14-294 14w=0 light	up to 825

¹In-line Power Supply is estimated at 90% Efficiency for LED HI-Bay Lamp System Watts
²Assumes 90% Efficiency for HID Ballast – older ballasts will produce higher System Watts comparison

Please visit our website for Technical Specifications (LM79/LM80/TM21) • Call for IES files and test data.

*For additional Color Temperatures, greater CRI please contact our sales and engineering team.

**The Bonneville Power Administration (BPA) has reviewed and approved the mogul based LED's submitted by GPE and is currently accepting them and offering incentives through the non-residential lighting program.



The LED HI-Bay is a direct replacement LED Lamp for E39/E40 mogul base HID bulbs in most indoor low/high bay fixtures.^{1,2}

GENPRO ENERGY SOLUTIONS
13261 Timberline Plaza, Ste B
Piedmont, SD 57769

1-866-593-0777
(605) 341-9918

www.genproenergy.com

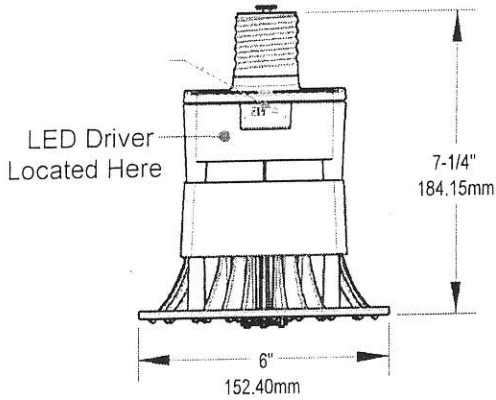

HI-BAY GPE-600750
SHOWN WITHOUT LENS
2lb. 5.6oz.
1.07kg

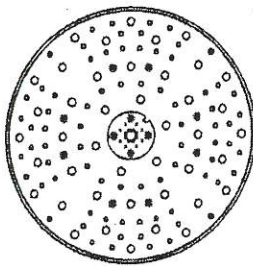

Specifications

MODEL	GPE-XXXXXX
INPUT POWER (WATTS)	148-294
HID EQUIVALENT SYSTEM POWER (WATTS)	450-825
INPUT LINE VOLTAGE (VAC)	110-277
INPUT FREQUENCY (Hz)	50-60
BASE TYPE	MOGUL
LUMENS	9706-21714
LUMEN EFFICACY (LPW)	74
CCT	4500K
CRI	76
RATED LIFE (HOURS)	50,000
POWER FACTOR @ 120 VAC	0.997
NUMBER OF LED'S	42
LED TYPE	CREE XM-L2
WARRANTY	5 year Non-Prorated + 5 year Limited

Note: Light output can be dialed downward via a user-accessible screw-adjustment, with resulting power savings and increased efficiency. Specifications shown for maximum output level.

Isoillumination Plots, Mounting Height 25'

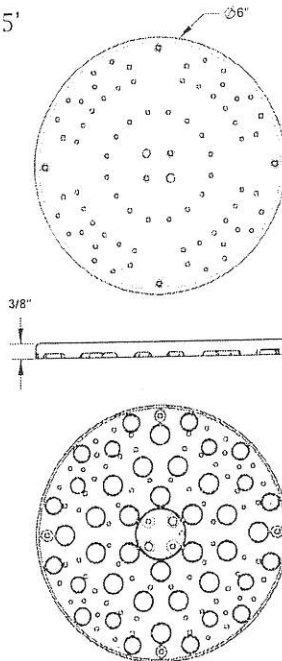
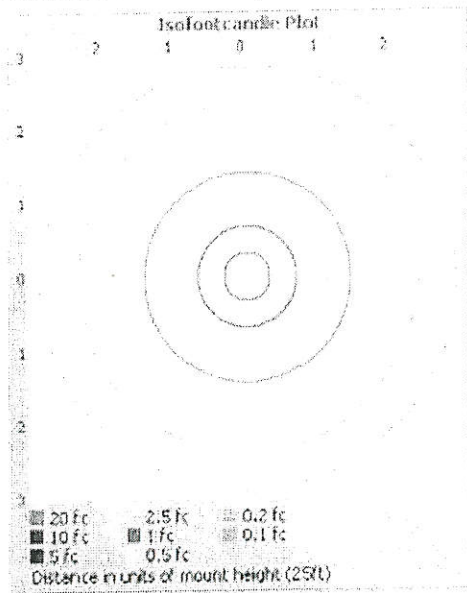

42 LED HI-BAY
MICRO-PRISM LENS

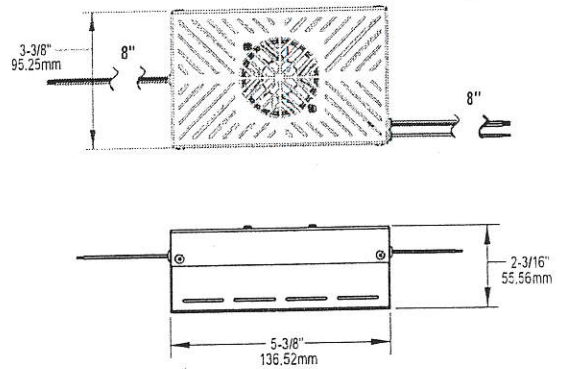
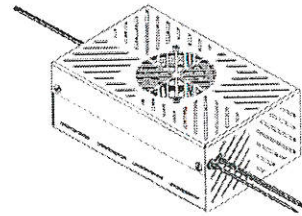

AC TO 48VDC POWER SUPPLY

SYSTEM WITH APPROVED POWER SUPPLY
CONFORMS TO:
FCC/CISPR 22:2008 Class A.
Conducted and Radiated Emissions

Note: When installing LED HI-Bay to replace HID bulb, ballast must be removed and recycled when present and the GPE approved AC/DC power supply installed in its place. Eliminating the ballast saves additional costs related to maintenance, energy consumption and performance and may be required by code.

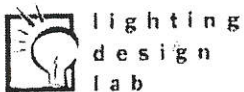

RECOGNIZED
COMPONENT



Intertek



RFP

To: Koch Hazard
431 N. Phillips
Suite 200
Sioux Falls, SD 57104
Ph: (605)336-3718 Fax: (605)336-0438

Number: 70
Date: 7/1/15
Job: 34-345 Huron- Washington Elem School
Phone:

Description: Retrofit light fixtures in Commons

We are pleased to offer the following specifications and pricing to make the following changes:

Retrofit existing light fixtures in Commons to LED.

The total amount to provide this work is \$4,690.00

The schedule is not affected by this change.

If you have any questions, please contact me at .

Submitted by: Kevin Bender

Approved by: _____
Date: _____

Cc:

34-345 Huron- Washington Elem School

RFP - 70
Retrofit light fixtures in Commons

Print Date 7/1/2015

Welfl Construction Corporation

<u>Number</u>	<u>Date</u>	<u>Description</u>	<u>Labor</u>	<u>Material</u>	<u>Sub</u>	<u>Total</u>
70	7/1/15	Retrofit light fixtures in Commons			4,295.00	4,295.00
		Electrical				0.00
		Sales Tax				0.00
		Payroll Tax				257.70
		OH on Sub Work				0.00
		OH on WCC Work				39.47
		Bond & Builders Risk				98.27
		Excise Tax				-0.44
		Rounding				

Total Price RFP - 70

\$4,690.00



Muth Electric Inc.



307 Dakota Avenue North • P.O. Box 1437 • Huron, SD 57350
PHONE (605) 352-8579 • FAX (605) 352-0939
www.muthelectric.com

June 30, 2015

Welfl Construction
Attn: Kevin Bender
800 West 23rd St.
Yankton, SD 57078

RE: Washington School
RFP 070
Huron, SD

Dear Kevin,

Our price to install LED lamps in 9 existing fixtures in existing gym and retrofit as per RFP 070 is:

ADD: \$4,295.00

If you have any questions or comments, please feel free to call me at (605) 352-8579.
We appreciate the opportunity to work with you.

MUTH ELECTRIC, INC.

Tom Sandve
Division Manager

Acceptance of Proposal - The above prices, specifications and conditions are satisfactory and are hereby accepted. You are authorized to do the work as specified by the receiving of this faxed notice signature from you.

Date of Acceptance: _____

Signature: _____

"Professional Answers For All Your Electrical Needs"

CORPORATE
(605) 996-3983

MITCHELL, SD
(605) 996-7300

SIoux FALLS, SD
(605) 338-6586

RAPID CITY, SD
(605) 341-3554

WATERTOWN, SD
(605) 882-2680

ABERDEEN, SD
(605) 226-8424

BROOKINGS, SD
(605) 692-0800

OMAHA, NE
(402) 551-7780

WILLISTON, ND
(701) 577-7300

Muth Electric, Inc.

Bid Summary Sheet

Estimate #: 32210 Location: Huron Muth Job Number: 5258
 Customer: Welf Construction Address: 1451 McClellan Drive
 Description: Washington School - RFP070
 Estimated By: Tom S. Checked By: Tom S. Estimate Date: 6/29/2015 Revision Date:
 Submission Date Change Order Status Approved Proposed GC C/O #
 Executed Void Muth C/O #:
 Approval Date

	Hours		Material Cost	Labor Hours
Coordination Time		Total from Estimate Item Detail	\$2,842.56	14.18
Foreman Time:	1.00	Misc Material and Labor: 3.00 %	\$85.28	0.43
Travel Time:	0.00	Coordination Time		1.00
Miscellaneous Time:	0.00	TOTAL MATERIAL (C) AND LABOR (D)	\$2,927.84	15.60
Total (A)	1.00	15.60 Regular Labor Hours @ \$36.00		\$561.61

Job Expense		
Tools, Scaffolds - 10 % of Labor Total		\$74.13
Safety- 6 % of Labor Total		\$44.48
Clean Up - 4 % of Labor Total		\$29.65
Warranty - 3 % of Labor Total		\$22.24
Temporary Power		\$0.00
Cutting, Patching, Painting		\$0.00
Use/Sales Tax 6.00 %		\$175.67
Inspection and Permit Fees		\$0.00
Field Incentive \$0.50 per hour		\$7.80
Material Storage		\$0.00
Freight		\$25.00
Mileage 0 Miles @ \$0.80 per Mile		\$0.00
Trenching 0 ft. @ 0 per ft.:		\$0.00
Plowing 0 ft. @ 0 per ft.:		\$0.00
Backhoe 0 ft. @ 0 per ft.		\$0.00
Equipment/Tools		\$0.00
Muth Equipment 0 Units: x \$0.00 Rate		\$0.00
Muth Equipment #2 0 Units: x \$0.00 Rate		\$0.00
Meals/ Lodging		\$0.00
Total Job Expenses (B)		\$378.97

0.00 Overtime Hours @ \$0.00	\$0.00
Labor Burden 32%	\$179.71
Labor Total	\$741.32
Subcontracts	\$0.00
Job Expense (B)	\$378.97
Material Cost	\$2,927.84
Total Direct Cost	\$4,048.13
Overhead 3 %	\$121.44
Sub Total	\$4,169.57
Profit 3 %	\$125.09
Sub Total	\$4,294.66
SD Contractors Excise Tax 0 %	\$0.00
Sub Total	\$4,294.66
Performance Bond	\$0.00
Total	\$4,294.66

SubContractor Report		
Subcontractor Name:	Phase:	Amount:
None	0	\$0.00
		\$0.00

Muth Electric - Estimate Detail Report

Muth Job Number: 5258

Estimate#: 32210 Estimated By: Tom S.

Customer: Well Construction

Job Desc: Washington School - RFP070

Location: Huron

Muth Item #	Description	Quantity	Labor Units	Labor Units Extension
	LED LAMPS - GEN	9	0.2100	1.89
	RETROFIT EXISTI	9	1.3650	12.29
	Totals			14.18



KOCH HAZARD
ARCHITECTS

REQUEST FOR PROPOSAL (RFP)

RFP 071

DATE: 30 June 2015

TO: Welf Construction Company

PROJECT: Washington Elementary School Addition and Renovation/#1277A
Huron School District 2-2
Huron, South Dakota

Owner Requested: _____ Contractor Requested: _____ Unforeseen Conditions Design Issue _____

Proposal Requests are for information only. Do not consider them instructions either to stop work in progress or to execute the proposed change.

Please submit an itemized cost breakdown, in accordance with the General Conditions, for changes in contract sum and contract time, resulting from the following proposed modification(s) to the Contract Documents.

PLEASE SUBMIT PROPOSAL WITHIN TEN (10) DAYS OR LESS

DESCRIPTION OF WORK:

Provide an itemized proposal for the following:

1. CATV System: Add two additional CATV amplifiers and adjust tap settings to provide acceptable signal strengths at outlets in the building.

ARCHITECT - KOCH HAZARD

Chris Brockevelt, Project Developer

REPRESENTATIVE

CC: Kelly Christopherson, Business Manager, Huron School District
Norm deWit, ACEI
Brad Shoup, ACEI
Randy Hoscheid, Pierce & Harris Engineering
Rob Maher, SEA
Chris Brockevelt, Koch Hazard Architects
Koch Hazard Architects log



RFP

To: Koch Hazard
431 N. Phillips
Suite 200
Sioux Falls, SD 57104
Ph: (605)336-3718 Fax: (605)336-0438

Number: 71
Date: 7/8/15
Job: 34-345 Huron- Washington Elem School
Phone:

Description: CATV amplifiers.

We are pleased to offer the following specifications and pricing to make the following changes:
CATV System: Add two additional CATV amplifiers and adjust tap settings to provide acceptable signal strengths at outlets in the building.

The total amount to provide this work is \$2,563.00

The schedule is not affected by this change.

If you have any questions, please contact me at .

Submitted by: Kevin Bender

Approved by: _____
Date: _____

Cc:

34-345 Huron- Washington Elem School

RFP - 71
CATV amplifiers.

Print Date 7/8/2015

Welfl Construction Corporation

<u>Number</u>	<u>Date</u>	<u>Description</u>	<u>Labor</u>	<u>Material</u>	<u>Sub</u>	<u>Total</u>
71	7/8/15	CATV amplifiers.			2,347.00	2,347.00
		<i>Electrical Work</i>				0.00
		<i>Sales Tax</i>				0.00
		<i>Payroll Tax</i>				140.82
		<i>OH on Sub Work</i>				0.00
		<i>OH on WCC Work</i>				21.57
		<i>Bond & Builders Risk</i>				53.70
		<i>Excise Tax</i>				-0.09
		<i>Rounding</i>				

Total Price RFP - 71

\$2,563.00



Muth Electric Inc.



307 Dakota Avenue North • P.O. Box 1437 • Huron, SD 57350
PHONE (605) 352-8579 • FAX (605) 352-0939
www.muthelectric.com

July 8, 2015

Welfl Construction
Attn: Kevin Bender
800 West 23rd St.
Yankton, SD 57078

RE: Washington School
RFP 071
Huron, SD

Dear Kevin,

Our price for the electrical work for RFP 071 is:

ADD: \$2,347.00

If you have any questions or comments, please feel free to call me at (605) 352-8579.
We appreciate the opportunity to work with you.

MUTH ELECTRIC, INC.

Tom Sandve
Division Manager

Acceptance of Proposal - The above prices, specifications and conditions are satisfactory and are hereby accepted. You are authorized to do the work as specified by the receiving of this faxed notice signature from you.

Date of Acceptance: _____

Signature: _____

"Professional Answers For All Your Electrical Needs"

CORPORATE
(605) 996-3983

MITCHELL, SD
(605) 996-7300

SIOUX FALLS, SD
(605) 338-6586

RAPID CITY, SD
(605) 341-3554

WATERTOWN, SD
(605) 882-2680

ABERDEEN, SD
(605) 226-8424

BROOKINGS, SD
(605) 692-0800

OMAHA, NE
(402) 551-7780

WILLISTON, ND
(701) 577-7300

Muth Electric, Inc.

Bid Summary Sheet

Estimate #: 32261 Location: Huron

Muth Job Number: 5258

Customer: Wellf Construction

Address: 1451 McClellan Drive

Description: Washington School - RFP071

Estimated By: Tom S. Checked By: Tom S.

Estimate Date: 7/7/2015

Revision Date:

Submission Date

Change Order Status

Approved Proposed
 Executed Void

GC C/O #

Muth C/O #:

Approval Date

Coordination Time	Hours
Foreman Time:	1.00
Travel Time:	0.00
Miscellaneous Time:	0.00
Total (A)	1.00

	Material Cost	Labor Hours
Total from Estimate Item Detail	\$18.15	2.20
Misc Material and Labor: 3.00 %	\$0.54	0.07
Coordination Time		1.00
TOTAL MATERIAL (C) AND LABOR (D)	\$18.69	3.26
3.26 Regular Labor Hours @ \$36.00		\$117.45

Job Expense		
Tools, Scaffolds - 10 % of Labor Total		\$15.50
Safety- 6 % of Labor Total		\$9.30
Clean Up - 4 % of Labor Total		\$6.20
Warranty - 3 % of Labor Total		\$4.65
Temporary Power		\$0.00
Cutting, Patching, Painting		\$0.00
Use/Sales Tax 6.00 %		\$1.12
Inspection and Permit Fees		\$0.00
Field Incentive \$0.50 per hour		\$1.63
Material Storage		\$0.00
Freight		\$0.00
Mileage 0 Miles @ \$0.80 per Mile		\$0.00
Trenching 0 ft. @ 0 per ft.:		\$0.00
Plowing 0 ft. @ 0 per ft.:		\$0.00
Backhoe 0 ft. @ 0 per ft.		\$0.00
Equipment/Tools		\$0.00
Muth Equipment 0 Units: x \$0.00 Rate		\$0.00
Muth Equipment #2 0 Units: x \$0.00 Rate		\$0.00
Meals/ Lodging		\$0.00
Total Job Expenses (B)		\$38.41

0.00 Overtime Hours @ \$0.00		\$0.00
Labor Burden 32%		\$37.58
Labor Total		\$155.03
Subcontracts		\$2,000.00
Job Expense (B)		\$38.41
Material Cost		\$18.69
Total Direct Cost		\$2,212.13
Overhead 3 %		\$66.36
Sub Total		\$2,278.49
Profit 3 %		\$68.35
Sub Total		\$2,346.84
SD Contractors Excise Tax 0 %		\$0.00
Sub Total		\$2,346.84
Performance Bond		\$0.00
Total		\$2,346.84

SubContractor Report		
Subcontractor Name:	Phase:	Amount:
DLH	0	\$2,000.00
		\$2,000.00

Muth Electric - Estimate Detail Report

Muth Job Number: 5258

Estimate#: 32261 Estimated By: Tom S.

Customer: Welfl Construction

Job Desc: Washington School - RFP071

Location: Huron

Muth Item #	Description	Quantity	Labor Units	Labor Units Extension
EMT50	1/2" EMT CONDUIT	15	0.0391	0.59
SSCNS50	1/2" EMT SS IT CO	2	0.0805	0.16
SSCPS50	1/2" EMT SS COU	1	0.0391	0.04
1H50	1/2" EMT 1 HOLE	2	0.0391	0.08
521715075	4 SQ 2 1/8 - 1/2 &	1	0.1978	0.20
CR20	CS DUPLEX OUTL	1	0.2588	0.26
RS12802	4SQ SINGLE DUP-	1	0.1277	0.13
GRPIG	GROUNDING PIG	1	0.0518	0.05
RED	WIRENUT RED	3	0.0046	0.01
PLANC	1/4" PLASTIC ANC	4	0.0495	0.20
SLOX10010	1X10 SCREWLOX	4	0.0322	0.13
THHN12	#12 THHN COPPE	50	0.0055	0.28
QO120	SQ D 20 AMP 1 P	1	0.1058	0.11
Totals				2.24



KOCH HAZARD
ARCHITECTS

REQUEST FOR PROPOSAL (RFP)

RFP 072

DATE: 07 July 2015

TO: Welfl Construction Company

PROJECT: Washington Elementary School Addition and Renovation/#1277A
Huron School District 2-2
Huron, South Dakota

Owner Requested: Contractor Requested: _____ Unforeseen Conditions _____ Design Issue _____

Proposal Requests are for information only. Do not consider them instructions either to stop work in progress or to execute the proposed change.

Please submit an itemized cost breakdown, in accordance with the General Conditions, for changes in contract sum and contract time, resulting from the following proposed modification(s) to the Contract Documents.

PLEASE SUBMIT PROPOSAL WITHIN TEN (10) DAYS OR LESS

DESCRIPTION OF WORK:

Provide an itemized proposal for the following for painting Room 160 Commons:

1. Patch existing holes in the brick and paint.

ARCHITECT - KOCH HAZARD

Chris Brockevelt, Project Developer

REPRESENTATIVE

CC: Kelly Christopherson, Business Manager, Huron School District
Norm deWit, ACEI
Brad Shoup, ACEI
Randy Hoscheid, Pierce & Harris Engineering
Rob Maher, SEA
Chris Brockevelt, Koch Hazard Architects
Koch Hazard Architects log



RFP

To: Koch Hazard
431 N. Phillips
Suite 200
Sioux Falls, SD 57104
Ph: (605)336-3718 Fax: (605)336-0438

Number: 72
Date: 7/23/15
Job: 34-345 Huron- Washington Elem School
Phone:

Description: Paint existing brick in Commons 160

We are pleased to offer the following specifications and pricing to make the following changes:
Patch existing holes in the brick and paint.

The total amount to provide this work is \$1,564.00

The schedule is not affected by this change.

If you have any questions, please contact me at .

Submitted by: Kevin Bender

Approved by: _____
Date: _____

Cc:

34-345 Huron- Washington Elem School

RFP - 72
Paint existing brick in Commons 160

Print Date 7/23/2015

Welfl Construction Corporation

<u>Number</u>	<u>Date</u>	<u>Description</u>	<u>Labor</u>	<u>Material</u>	<u>Sub</u>	<u>Total</u>
72	7/23/15	Paint existing brick in Commons 160				
		Masonry	288.00	25.00		313.00
		Painting			1,000.00	1,000.00
		Sales Tax				1.50
		Payroll Tax				118.08
		OH on Sub Work				60.00
		OH on WCC Work				25.04
		Bond & Builders Risk				13.16
		Excise Tax				32.76
		Rounding				0.46
					Total Price RFP - 72	\$1,564.00

TELEPHONE BID

DATE 7-23-15

JOB Washinton Elementary

LOCATION Huron, SD

FIRM Bachman Painting

BY Larry

PHONE 881-5851

ADDRESS

CLASS
OF WORK

WORK INCLUDED

AMOUNT OF BID

RFP #72 Paint existing brick in Commons 160 \$1,000¹⁰⁰/₁₀₀

TOTAL BID \$1,000¹⁰⁰/₁₀₀

EXCLUSIONS AND QUALIFICATIONS

ACKNOWLEDGEMENT
OF ADDENDA:

DELIVERY:

TAX

EXCLUDED

INCLUDED

RECEIVED BY:



KOCH HAZARD
ARCHITECTS

REQUEST FOR PROPOSAL (RFP)

RFP 073

DATE: 22 July 2015

TO: Welfl Construction Company

PROJECT: Washington Elementary School Addition and Renovation/#1277A
Huron School District 2-2
Huron, South Dakota

Owner Requested: _____ Contractor Requested: _____ Unforeseen Conditions _____ Design Issue _____

Proposal Requests are for information only. Do not consider them instructions either to stop work in progress or to execute the proposed change.

Please submit an itemized cost breakdown, in accordance with the General Conditions, for changes in contract sum and contract time, resulting from the following proposed modification(s) to the Contract Documents.

PLEASE SUBMIT PROPOSAL WITHIN TEN (10) DAYS OR LESS

DESCRIPTION OF WORK:

1. Provide an itemized proposal for deleting the acoustical ceiling tile in room 106.

ARCHITECT - KOCH HAZARD

Chris Brockvelt, Project Developer

REPRESENTATIVE

CC: Kelly Christopherson, Business Manager, Huron School District
Norm deWit, ACEI
Brad Shoup, ACEI
Randy Hoscheid, Pierce & Harris Engineering
Rob Maher, SEA
Chris Brockvelt, Koch Hazard Architects
Koch Hazard Architects log



RFP

To: Koch Hazard
431 N. Phillips
Suite 200
Sioux Falls, SD 57104
Ph: (605)336-3718 Fax: (605)336-0438

Number: 73
Date: 7/27/15
Job: 34-345 Huron- Washington Elem School
Phone:

Description: Deleting acc tile ceiling in 106.

We are pleased to offer the following specifications and pricing to make the following changes:
Delete acoustical ceiling tile and grid in room 106. Utilize existing light fixtures with chain hanging the fixtures.

The total amount to provide this work is \$-170.00

The schedule is not affected by this change.

If you have any questions, please contact me at .

Submitted by: Kevin Bender

Approved by: _____
Date: _____

Cc:

34-345 Huron- Washington Elem School

RFP - 73
Deleting acc tile ceiling in 106.

Print Date 7/27/2015

Welfl Construction Corporation

<u>Number</u>	<u>Date</u>	<u>Description</u>	<u>Labor</u>	<u>Material</u>	<u>Sub</u>	<u>Total</u>
73	7/27/15	Deleting acc tile ceiling in 106.				
		Acoustical Ceiling			-392.00	-392.00
		Electrical			227.00	227.00
		Sales Tax				0.00
		Payroll Tax				0.00
		OH on Sub Work				0.00
		OH on WCC Work				0.00
		Bond & Builders Risk				-1.43
		Excise Tax				-3.56
		Rounding				-0.01
					Total Price RFP - 73	\$-170.00

Dakota Acoustical Tile Change Order

JOB NAME	WASHINGTON ELEM		
LOCATION	HURON, SD		
CHANGE NUMBER	RFP# 073		
DESCRIPTION OF CHANGE	DELETE ROOM 106		
ATTN: KEVIN			
GENERAL: WELFL CONSTRUCTION			
LABOR	MAN HOURS	RATE	EXTENSION
CARPENTER ACOUST TILE CLGS	-4	\$20.00	(\$80.00)
CARPENTER ACOUSTICAL OT		\$0.00	\$0.00
TAPER		\$0.00	\$0.00
			\$0.00
SUBTOTAL		8.50%	(\$6.80)
FUI/SUI		11.00%	(\$8.80)
WORKER'S COMP.		7.65%	(\$6.12)
FICA			\$0.00
SUBTOTAL LABOR			(\$101.72)
PER DIEM	0	\$20.00	\$0.00
MATERIALS	QUANTITY	UNIT COST	EXTENSION
CELSHM154 2X2 SAND MICRO TEG	-192	\$0.650	(\$124.80)
CMC211-01 2X2 GRID	-208	\$0.400	(\$83.20)
MISC ATTACHMENTS	-208	\$0.100	(\$20.80)
	0	\$0.000	\$0.00
WALL ANGLE 12'	-60	\$0.290	(\$17.40)
		\$0.000	\$0.00
		\$0.000	\$0.00
		\$0.000	\$0.00
		\$0.000	\$0.00
		\$0.000	\$0.00
		\$0.000	\$0.00
		\$0.000	\$0.00
		\$0.000	\$0.00
		\$0.000	\$0.00
		\$0.000	\$0.00
		\$0.000	\$0.00
		\$0.000	\$0.00
		\$0.000	\$0.00
		\$0.000	\$0.00
		\$0.000	\$0.00
		\$0.000	\$0.00
		\$0.000	\$0.00
		\$0.000	\$0.00
		\$0.000	\$0.00
		\$0.000	\$0.00
		\$0.000	\$0.00
SUBTOTAL MATERIALS			(\$246.20)
STATE & LOCAL TAXES		6.00%	(\$14.77)
TOTAL MATERIALS			(\$260.97)
TOTAL LABOR			(\$101.72)
SUBTOTAL MATERIALS & LABOR			(\$362.69)
OVERHEAD		8.00%	(\$29.02)
SUB-TOTAL			(\$391.71)
FEE		0.00%	\$0.00
TOTAL QUOTE (ROUND OFF)			(\$392)



Muth Electric Inc.



307 Dakota Avenue North • P.O. Box 1437 • Huron, SD 57350
PHONE (605) 352-8579 • FAX (605) 352-0939
www.muthelectric.com

July 24, 2015

Welfl Construction
Attn: Kevin Bender
800 West 23rd St.
Yankton, SD 57078

RE: Washington School
RFP 073
Huron, SD

Dear Kevin,

Our price for the electrical work for RFP 073 is:

ADD: \$227.00

If you have any questions or comments, please feel free to call me at (605) 352-8579.
We appreciate the opportunity to work with you.

MUTH ELECTRIC, INC.

Tom Sandve
Division Manager

Acceptance of Proposal - The above prices, specifications and conditions are satisfactory and are hereby accepted. You are authorized to do the work as specified by the receiving of this faxed notice signature from you.

Date of Acceptance: _____

Signature: _____

"Professional Answers For All Your Electrical Needs"

CORPORATE
(605) 996-3983

MITCHELL, SD
(605) 996-7300

SIOUX FALLS, SD
(605) 338-6586

RAPID CITY, SD
(605) 341-3554

WATERTOWN, SD
(605) 882-2680

ABERDEEN, SD
(605) 226-8424

BROOKINGS, SD
(605) 692-0800

OMAHA, NE
(402) 551-7780

WILLISTON, ND
(701) 577-7300

Muth Electric, Inc.

Bid Summary Sheet

Estimate #: 32406 Location: Huron

Muth Job Number: 5258

Customer: Wellf Construction

Address 1451 McClellan Drive

Description: Washington School - RFP073

Estimated By: Tom S.

Checked By: Tom S.

Estimate Date: 7/23/2015

Revision Date:

Submission Date

Change Order
Status

Approved

Proposed

GC C/O #

Executed

Void

Muth C/O #:

Approval Date

Coordination Time	Hours
Foreman Time:	0.00
Travel Time:	0.00
Miscellaneous Time:	0.00
Total (A)	0.00

	Material Cost	Labor Hours
Total from Estimate Item Detail	\$40.09	2.81
Misc Material and Labor: 3.00 %	\$1.20	0.08
Coordination Time		0.00
TOTAL MATERIAL (C) AND LABOR (D)	\$41.29	2.89
2.89 Regular Labor Hours @ \$36.00		\$104.05

Job Expense		
Tools, Scaffolds - 10 % of Labor Total		\$13.73
Safety- 6 % of Labor Total		\$8.24
Clean Up - 4 % of Labor Total		\$5.49
Warranty - 3 % of Labor Total		\$4.12
Temporary Power		\$0.00
Cutting, Patching, Painting		\$0.00
Use/Sales Tax 6.00 %		\$2.48
Inspection and Permit Fees		\$0.00
Field Incentive \$0.50 per hour		\$1.45
Material Storage		\$0.00
Freight		\$0.00
Mileage 0 Miles @ \$0.80 per Mile		\$0.00
Trenching 0 ft. @ 0 per ft.:		\$0.00
Plowing 0 ft. @ 0 per ft.:		\$0.00
Backhoe 0 ft. @ 0 per ft.		\$0.00
Equipment/Tools		\$0.00
Muth Equipment 0 Units: x \$0.00 Rate		\$0.00
Muth Equipment #2 0 Units: x \$0.00 Rate		\$0.00
Meals/ Lodging		\$0.00

0.00 Overtime Hours @ \$0.00	\$0.00
Labor Burden 32%	\$33.29
Labor Total	\$137.34
Subcontracts	\$0.00
Job Expense (B)	\$35.51
Material Cost	\$41.29
Total Direct Cost	\$214.14
Overhead 3 %	\$6.42
Sub Total	\$220.56
Profit 3%	\$6.62
Sub Total	\$227.17
SD Contractors Excise Tax 0 %	\$0.00
Sub Total	\$227.17
Performance Bond	\$0.00
Total	\$227.17

Total Job Expenses (B)	\$35.51
-------------------------------	----------------

SubContractor Report

Subcontractor Name:	Phase:	Amount:
None	0	\$0.00
		\$0.00

Muth Electric - Estimate Detail Report

Muth Job Number: 5258

Estimate#: 32406 Estimated By: Tom S.

Customer: Welfl Construction

Job Desc: Washington School - RFP073

Location: Huron

Muth Item #	Description	Quantity	Labor Units	Labor Units Extension
GPL20010	HANG FAST #3 20	6	0.1610	0.97
	EYE BOLT	6	0.1150	0.69
	REROUTE - COND	1	1.1500	1.15
Totals				2.81

HURON MIDDLE SCHOOL GUIDELINES FOR iPad USE

Huron School District is proud to offer our 8th Grade Huron Middle School students Apple iPads devices for use at school. The 1:1 iPad Program, which provides mobile computing and wireless technology to all 8th Grade Middle School students, has been designed to enhance the delivery and individualization of instruction. The focus of the iPad program at Huron Middle School is to provide tools and resources to the 21st Century Learner.

The guidelines, procedures, and information in this document are in addition to the Huron Middle Schools Responsible Usage Policy and Internet Usage Policy. Teachers may set additional requirements for iPad use in their classroom.

A. General Precautions and Rules for iPad Use

1. The iPad is school property that you are being allowed to use.
2. Students are responsible for keeping their iPad in good working order.
3. Any damage to the iPad should be reported by contacting the school Principal.
4. Use only a soft cloth to clean the screen, no cleaners of any kind.
5. No writing or stickers should be applied by the student.
6. Sound must be muted at all times unless permission has been given by a teacher. Earbuds may be used only when permission has been given by a teacher.
7. Music should only be accessed only if permission is given by a teacher.
8. Gaming is not allowed on the iPad unless directed by a teacher.
9. Students are not to take photos or video unless it is being used in a project.
10. Students are not to use any social media sites during school
11. No iPads in the restrooms, locker rooms, or at lunch.
12. Only school appropriate backgrounds and screen savers may be used on the iPads. Examples of inappropriate backgrounds include the presence of weapons-related materials, pornographic materials, inappropriate language, alcohol, drug, gang-related symbols, etc... These types of pictures on the iPad or within its files will result in disciplinary action and where appropriate, referral to law enforcement.
13. Passwords on lock screen are not to be used. The iPad is the property of the school district. Therefore, school staff members have the right to check any material stored on a student's iPad at any time.
14. No Printing is allowed on school issued iPads.
15. It is the student's responsibility to ensure that work is not lost due to technical failure or accidental deletion. iPads malfunctions are not an acceptable excuse for not submitting work. All important files and projects should be backed up on eBackpack.
16. The apps originally installed must remain on the iPad in usable condition and be easily accessible at all times.
17. Student iPads will be filtered through the districts Internet content filter. (iPads are monitored remotely at all times.)
18. Lockers are to be locked when storing your iPad. (Must be stored in your locker at lunch.)
19. Unsupervised iPads will be confiscated by staff and taken to the middle school office. Each student is responsible for his or her iPad once it has been issued.
20. All iPads are to be left in 1st CORE Class at the end of the day and must be plugged in. It is the student's responsibility to make sure they are charged and ready for the next day. Students will pick up their device each morning from their 1st CORE Class.

Key Commitments:

- I will not access or display materials on the iPad – websites, apps, games, videos, images, music, etc. – while on school grounds that are inappropriate for the school environment or my age group. (ex. Profanity, weapons/violence/blood, sexual content, alcohol/drug use, etc.)
- I will not acquire and/or share images, audio, or video of others without their express permission.
- I will not use my iPad outside during lunch or other non-class times unless under the direct permission and supervision of a teacher.
- I will not play games on the iPad during the school day unless I have specific permission from my teacher or administrator.
- I will not access, upload, download, share, or distribute offensive, profane, threatening, pornographic, obscene, or sexually explicit materials for any reason.
- I will not share my Apple ID or any other account information with others, nor use my Apple ID or other account information on someone else's device.
- My sound will be muted at all times unless my teacher gives me permission to use the sound or headphones.
- I will not touch or use other people's devices (including hardware, apps, media, etc.) without their express permission.
- I will not access (or attempt to access) the accounts, files, data, apps, media, etc. of any students or teachers.

Appropriate Classroom Use

- 1) Each class will begin with iPads put face down on the desk, or below the desk depending on the classroom.**
- 2) Teachers who begin the day with an iPad activity will give specific instructions for this activity.**
- 3) Students will not use any gaming or social media applications during school.**
- 4) Students must have volume on mute or use Earbuds for instructional purposes with teacher permission.**
- 5) Student's iPad screens are to be visible to the teacher at all times.**
- 6) NO iPads in the Restrooms, at Lunch or in the Locker Rooms.**

Consequences for iPad use Infraction:

Actions that violate any of the items in the Respectable Use Policy, Internet Usage Policy, iPad Guidelines or individual classroom teacher iPad policies will result in:

1. 1st Offense – iPad Confiscated – principal referral – verbal warning.
2. 2nd Offense – iPad Confiscated – principal referral – 30 minute detention.
3. 3rd Offense & Beyond – iPad Confiscated – principal referral – 1 hour detention. iPad will be removed for one full day. Student is responsible for the same work through another mode. Parent/student conference.

Since the iPads are the property of Huron Middle School, officials of the school have the right to review all material stored on or accessed by any iPad. School officials may revoke a student's iPad use privileges for misuse or violation of policies.

Repairing or Replacing your iPad

Students will be responsible for damages to their iPads including, but not limited to, broken screens, cracked plastic pieces, inoperability, etc. Depending on the damage and whether or not the damage was accidental or due to a malfunction of maintenance issue, the Huron Middle School District Protection Plan would be used to determine the cost of the repairs. In the case of intentional damage and/or neglect, the student will pay the full repair or replacement cost of the device.

Insurance is available through Huron Middle School. The **cost of the insurance protection is \$30 annually per student**. Students with an accepted **Free/Reduced Lunch application on file** with the school nutrition office **will pay \$15 annually per student**. Checks must be made *payable to Huron Middle School*. The insurance policy covers one iPad per student per school year for any costs outside the manufacturer's warranty.

Claims	Fee with insurance
Lost iPad	\$200
Destroyed iPad (total loss)	\$200
Stolen iPad (Police Report Required)	\$200
iPad Repairs	50% of actual repair cost up to \$100
<i>Power adapter, lightening cord, cover or any school-owned accessories are not included.</i>	<i>These items require a full replacement cost with the exact same item.</i>

All protection plan claims for accidental damage or maintenance must be reported and filed with the Help Desk. In cases of theft or loss, students or parents must file a police report (School Resource Officer must be notified) and bring a copy of the report to the office before an iPad can be replaced with the Huron School District Protection Plan.

I ACKNOWLEDGE AND UNDERSTAND MY OBLIGATIONS:

Print User Name

User Signature

Date

Parent/Guardian Signature

Date



Huron Middle School iPad Agreement 2015-'16

July 20, 2015